

STEEL BUILDINGS IN EUROPE

Single-Storey Steel Buildings

Part 3: Actions

Single-Storey Steel Buildings

Part 3: Actions

FOREWORD

This publication is part three of a design guide, *Single-Storey Steel Buildings*.

The 10 parts in the *Single-Storey Steel Buildings* guide are:

- Part 1: Architect's guide
- Part 2: Concept design
- Part 3: Actions
- Part 4: Detailed design of portal frames
- Part 5: Detailed design of trusses
- Part 6: Detailed design of built up columns
- Part 7: Fire engineering
- Part 8: Building envelope
- Part 9: Introduction to computer software
- Part 10: Model construction specification
- Part 11: Moment connections

Single-Storey Steel Buildings is one of two design guides. The second design guide is *Multi-Storey Steel Buildings*.

The two design guides have been produced in the framework of the European project "Facilitating the market development for sections in industrial halls and low rise buildings (SECHALO) RFS2-CT-2008-0030".

The design guides have been prepared under the direction of Arcelor Mittal, Peiner Träger and Corus. The technical content has been prepared by CTICM and SCI, collaborating as the Steel Alliance.

Contents

	Page No
FOREWORD	iii
SUMMARY	vi
1 INTRODUCTION	1
2 SAFETY PHILOSOPHY ACCORDING TO EN 1990	2
2.1 General format of the verifications	2
2.2 Ultimate limit states and serviceability limit states	2
2.3 Characteristic values and design values of actions	3
3 COMBINATIONS OF ACTIONS	4
3.1 General	4
3.2 ULS combinations	4
3.3 SLS combinations	6
4 PERMANENT ACTIONS	8
5 CONSTRUCTION LOADS	9
6 IMPOSED LOADS	10
6.1 General	10
6.2 Actions induced by cranes according to EN 1991-3	10
6.3 Horizontal loads on parapets	15
7 SNOW LOADS	16
7.1 General	16
7.2 Methodology	16
8 WIND ACTIONS	22
8.1 General	22
8.2 Methodology	22
8.3 Flowcharts	31
9 EFFECT OF TEMPERATURE	32
REFERENCES	33
Appendix A Worked Example: Snow load applied on a single-storey building	35
Appendix B Worked Example: Wind action on a single-storey building	45

SUMMARY

This document provides guidelines for the determination of the actions on a single-storey building according to EN 1990 and EN 1991. After a short description of the general format for limit state design, this guide provides information on the determination of the permanent loads, the variable actions and the combinations of actions. The determination of the snow loads and the calculation of the wind action are described and summarized in comprehensive flowcharts. Simple worked examples on the snow loads and the wind action are also included.

1 INTRODUCTION

This guide provides essential information on the determination of the design actions on a single-storey building. It describes the basis of design with reference to the limit state concept in conjunction with the partial factor method, according to the following parts of the Eurocodes:

- EN 1990: Basis of structural design^[1].
- EN 1991: Actions on structures
 - Part 1-1: General actions – Densities, self-weight, imposed loads for buildings^[2].
 - Part 1-3: General actions – Snow loads^[3]
 - Part 1-4: General actions – Wind actions^[4]
 - Part 1-5: General actions – Thermal actions^[5]
 - Part 3: Actions induced by cranes and machinery.^[6]

The guide is a comprehensive presentation of the design rules applied to single-storey buildings with reference to the appropriate clauses, tables and graphs of the Eurocodes.

Additional information can be found in the references ^{[7][8]}.

2 SAFETY PHILOSOPHY ACCORDING TO EN 1990

2.1 General format of the verifications

A distinction is made between ultimate limit states (ULS) and serviceability limit states (SLS).

The ultimate limit states are related to the following design situations:

- Persistent design situations (conditions of normal use)
- Transient design situations (temporary conditions applicable to the structure, e.g. during execution, repair, etc.)
- Accidental design situations (exceptional conditions applicable to the structure)
- Seismic design situations (conditions applicable to the structure when subjected to seismic events). These events are dealt within EN 1998^[9], and are outside the scope of this guide.

The serviceability limit states concern the functioning of the structure under normal use, the comfort of people and the appearance of the construction.

The verifications shall be carried out for all relevant design situations and load cases.

2.2 Ultimate limit states and serviceability limit states

2.2.1 Ultimate limit states (ULS)

The states classified as ultimate limit states are those that concern the safety of people and /or the safety of the structure. The structure shall be verified at ULS when there is:

- Loss of equilibrium of the structure or any part of it (EQU)
- Failure by excessive deformation, rupture, loss of stability of the structure or any part of it (STR)
- Failure or excessive deformation of the ground (GEO)
- Failure caused by fatigue or other time-dependent effects (FAT).

2.2.2 Serviceability Limit States (SLS)

The structure shall be verified at SLS when there is:

- Deformations that affect the appearance, the comfort of users or the functioning of the structure
- Vibrations that cause discomfort to people or that limit the functional effectiveness of the structure
- Damage that is likely to adversely affect the appearance, the durability or the functioning of the structure.

2.3 Characteristic values and design values of actions

2.3.1 General

Actions shall be classified by their variation in time as follows:

- Permanent actions (G), e.g. self-weight of structures, fixed equipment, etc.
- Variable actions (Q), e.g. imposed loads, wind actions, snow loads, etc.
- Accidental actions (A), e.g. explosions, impact from vehicles, etc.

Certain actions may be considered as either accidental and/or variable actions, e.g. seismic actions, snow loads, wind actions with some design situations.

2.3.2 Characteristic values of actions

The characteristic value (F_k) of an action is its principal representative value. As it can be defined on statistical bases, it is chosen so as to correspond to a prescribed probability of not exceeding on the unfavourable side, during a 'reference period' taking into account the design working life of the structure.

These characteristic values are specified in the various Parts of EN 1991.

2.3.3 Design values of actions

The design value F_d of an action F can be expressed in general terms as:

$$F_d = \gamma_f \psi F_k$$

where:

F_k is the characteristic value of the action

γ_f is a partial factor for the action

ψ is either 1,00, ψ_0 , ψ_1 or ψ_2

2.3.4 Partial factors

Partial factors are used to verify the structures at ULS and SLS. They should be obtained from EN 1990 Annex A1, or from EN 1991 or from the relevant National Annex.

2.3.5 ψ factors

In the combinations of actions, ψ factors apply to variable actions in order to take into account the reduced probability of simultaneous occurrence of their characteristic values.

The recommended values for ψ factors for buildings should be obtained from EN 1990 Annex A1 Table A1.1, or from EN 1991 or from the relevant National Annex.

3 COMBINATIONS OF ACTIONS

3.1 General

The individual actions should be combined so as not to exceed the limit state for the relevant design situations.

Actions that cannot occur simultaneously, e.g. due to physical reasons, should not be considered together in a same combination.

Depending on its uses and the form and the location of a building, the combinations of actions may be based on not more than two variable actions – See Note 1 in EN 1990 § A1.2.1(1). The National Annex may provide additional information.

3.2 ULS combinations

3.2.1 Static equilibrium

To verify a limit state of static equilibrium of the structure (EQU), it shall be ensured that:

$$E_{d,dst} \leq E_{d,stab}$$

where:

$E_{d,dst}$ is the design value of the effect of destabilising actions

$E_{d,stab}$ is the design value of the effect of stabilising actions

3.2.2 Rupture or excessive deformation of an element

To verify a limit state of rupture or excessive deformation of a section, member or connection (STR and/or GEO), it shall be ensured that:

$$E_d \leq R_d$$

where:

E_d is the design value of the effect of actions

R_d is the design value of the corresponding resistance

Each combination of actions should include a leading variable action or an accidental action.

3.2.3 Combinations of actions for persistent or transient design situations

According to EN 1990 § 6.4.3.2(3), the combinations of actions can be derived either from expression (6.10) or from expressions (6.10a and 6.10b – whichever is more onerous). The choice between these two sets of expressions may be imposed by the National Annex.

In general, expression (6.10) is conservative in comparison to the pair of expressions (6.10a and 6.10b), but it leads to a reduced number of combinations to consider.

$$E_d = \sum_{j \geq 1} \gamma_{G,j} G_{k,j} + \gamma_{Q,1} Q_{k,1} + \sum_{i > 1} \gamma_{Q,i} \psi_{0,i} Q_{k,i} \quad (6.10)$$

$$E_d = \sum_{j \geq 1} \gamma_{G,j} G_{k,j} + \psi_{0,1} \gamma_{Q,1} Q_{k,1} + \sum_{i > 1} \gamma_{Q,i} \psi_{0,i} Q_{k,i} \quad (6.10a)$$

$$E_d = \xi \sum_{j \geq 1} \gamma_{G,j} G_{k,j} + \gamma_{Q,1} Q_{k,1} + \sum_{i > 1} \gamma_{Q,i} \psi_{0,i} Q_{k,i} \quad (6.10b)$$

G_k and Q_k are found in EN 1991 or its National Annex.

γ_G and γ_Q are found in Table A1.2(A) for static equilibrium (EQU); Tables A1.2(B) and A1.2(C) for rupture (STR and/or GEO) of EN 1990 or in the National Annex. Table 3.1 gives the recommended values of the partial factors.

Table 3.1 Recommended values of partial factors

Table (EN 1990)	Limit state	$\gamma_{Gj,inf}$	$\gamma_{Gj,sup}$	$\gamma_{Q,1} = \gamma_{Q,l}$	$\gamma_{Q,i} = \gamma_{Q,i}$
A1.2(A)	EQU	0,90	1,10	1,50	1,50
A1.2(B)	STR/GEO	1,00	1,35	1,50	1,50
A1.2(C)	STR/GEO	1,00	1,00	1,30	1,30

ψ_0 factors are found in EN 1990 Table A1.1 or in its National Annex. This factor varies between 0,5 and 1 except for roofs of category H ($\psi_0 = 0$).

ξ is a reduction factor for permanent loads. According to EN 1990 Table A1.2(B), the recommended value for buildings is $\xi = 0,85$. The National Annex may specify a different value.

For example, according to expression 6.10:

1. With snow as the leading variable action:

$$E_d = 1,35 G + 1,5 S + (1,5 \times 0,6) W = 1,35 G + 1,5 S + 0,9 W$$

2. With wind as the leading variable action:

$$E_d = 1,35 G + 1,5 W + (1,5 \times 0,5) S = 1,35 G + 1,5 W + 0,75 S$$

3.2.4 Combinations of actions for accidental design situations

Combinations of actions for accidental design situations should either involve an explicit accidental action or refer to a situation after an accident event.

$$E_d = \sum_{j \geq 1} G_{k,j} + A_d + (\psi_{1,1} \text{ or } \psi_{2,1}) Q_{k,1} + \sum_{i > 1} \gamma_{Q,i} \psi_{0,i} Q_{k,i}$$

The choice between $\psi_{1,1}Q_{k,1}$ or $\psi_{2,1}Q_{k,1}$ should be related to the relevant accidental design situation. Guidance is given in EN 1990 or in the National Annex to EN 1990.

3.3 SLS combinations

3.3.1 Serviceability Limit State

To verify a serviceability limit state, it shall be ensured that:

$$E_d \leq C_d$$

where:

E_d is the design value of the effects of actions specified in the serviceability criterion,

C_d is the limiting design value of the relevant serviceability criterion.

3.3.2 Characteristic combination

The characteristic combination is normally used for irreversible limit states.

	Permanent actions		Leading variable action		Accompanying variable actions
$E_d =$	$\sum_{j \geq 1} G_{k,j}$	+	$Q_{k,1}$	+	$\sum_{i > 1} \psi_{0,i} Q_{k,i}$

For example:

$$E_d = G + S + 0,6 W$$

$$E_d = G + W + 0,5 S$$

3.3.3 Frequent combination

The frequent combination is normally used for reversible limit states.

	Permanent actions		Leading variable action		Accompanying variable actions
$E_d =$	$\sum_{j \geq 1} G_{k,j}$	+	$\psi_{1,1} Q_{k,1}$	+	$\sum_{i > 1} \psi_{2,i} Q_{k,i}$

For example:

$$E_d = G + 0,2 S \quad (\psi_2 = 0 \text{ for the wind action})$$

$$E_d = G + 0,2 W \quad (\psi_2 = 0 \text{ for the snow load})$$

3.3.4 Quasi-permanent combination

The quasi-permanent combination is normally used for long-term effects and the appearance of the structure.

	Permanent actions		Variable actions
$E_d =$	$\sum_{j \geq 1} G_{k,j}$	+	$\sum_{i > 1} \psi_{2,i} Q_{k,i}$

For example:

$E_d = G$ (since $\psi_2 = 0$ for both the wind action and the snow load)

4 PERMANENT ACTIONS

The self-weight of construction works is generally the main permanent load. It should be classified as a permanent fixed action. In most cases, it should be represented by a single-characteristic value.

The total self-weight of structural and non-structural members, including fixed services, should be taken into account in combinations of actions as a single action.

Non-structural elements include roofing, surfacing and coverings, partitions and linings, hand rails, safety barriers, parapets, wall claddings, suspended ceilings, thermal insulation, fixed machinery and all fixed services (heating, ventilating, electrical and air conditioning equipment, pipes without their contents, cable trunking and conduits).

The characteristic values of self-weight should be defined from the dimensions and densities of the elements.

Values of densities of construction materials are provided in EN 1991-1-1 Annex A (Tables A.1 to A.5).

For example:

Steel: $\gamma = 77,0$ to $78,5$ kN/m³

Aluminium: $\gamma = 27,0$ kN/m³

For manufactured elements (façades, ceilings and other equipment for buildings), data may be provided by the manufacturer.

5 CONSTRUCTION LOADS

EN 1991-1-6 gives rules for the determination of the actions during execution. Verifications are required for both serviceability limit states and ultimate limit states.

Table 4.1 defines construction loads that have to be taken into account:

- Personnel and hand tools (Q_{ca})
- Storage of movable items (Q_{cb})
- Non permanent equipment (Q_{cc})
- Moveable heavy machinery and equipment (Q_{cd})
- Accumulation of waste material (Q_{ce})
- Loads from parts of structure in a temporary state (Q_{cf}).

Recommended values are provided in the same table but values may be given in the National Annex.

In single-storey buildings, an example of construction load would be the weight of cladding bundles on the structure prior to fitting.

6 IMPOSED LOADS

6.1 General

Generally, imposed loads on buildings shall be classified as variable actions. They arise from occupancy. They include normal use by persons, furniture and moveable objects, vehicles, anticipating rare events (concentrations of persons or of furniture, momentary moving or stacking of objects, etc.). Movable partitions should be treated as imposed loads.

Imposed loads are represented by uniformly distributed loads, line loads or point loads applied on roofs or floors, or a combination of these loads.

Floor and roof areas in buildings are sub-divided into categories according to their use (EN 1991-1-1 Table 6.1). The characteristic values q_k (uniformly distributed load) and Q_k (concentred load) related to these categories are specified in EN 1991-1-1 Table 6.2 or in the relevant National Annex.

For the design of a single floor or a roof, the imposed load shall be taken into account as a free action applied at the most unfavourable part of the influence area of the action effects considered.

For imposed loads for floors and accessible roofs, the characteristic value q_k may be multiplied by reduction factors due to the loaded area and the number of storeys (EN 1991-1-1 § 6.3.1.2). More information is provided in Section 6 of *Multi-storey steel buildings. Part 3: Actions*^[10].

Characteristic values of imposed loads are specified in EN 1991-1-1 Section 6.3 as follows:

6.3.1 Residential, social, commercial and administration areas

6.3.2 Areas for storage and industrial activities

6.3.3 Garages and vehicle traffic areas

6.3.4 Roofs.

6.2 Actions induced by cranes according to EN 1991-3

6.2.1 General

Most industrial buildings have to be equipped with handling devices to allow movement and carriage of loads through the building. A typical crane used in industrial buildings is shown in Figure 6.1 with the main technical terms.

One of the convenient solutions is the installation of cranes. The structure is subject to loads acting both vertically and laterally. Such actions can become the dominant ones for the structure.

The determination of the actions induced by cranes is complex, as they include many parameters such as:

- Weight of the crane and safe working load
- Stiffness of both the crane structure and the runway girders
- Speed and acceleration of the crane
- Design of the crane (wheel drives, guidance systems, etc.).

The characteristics of the crane generally have to be supplied by the crane manufacturers.

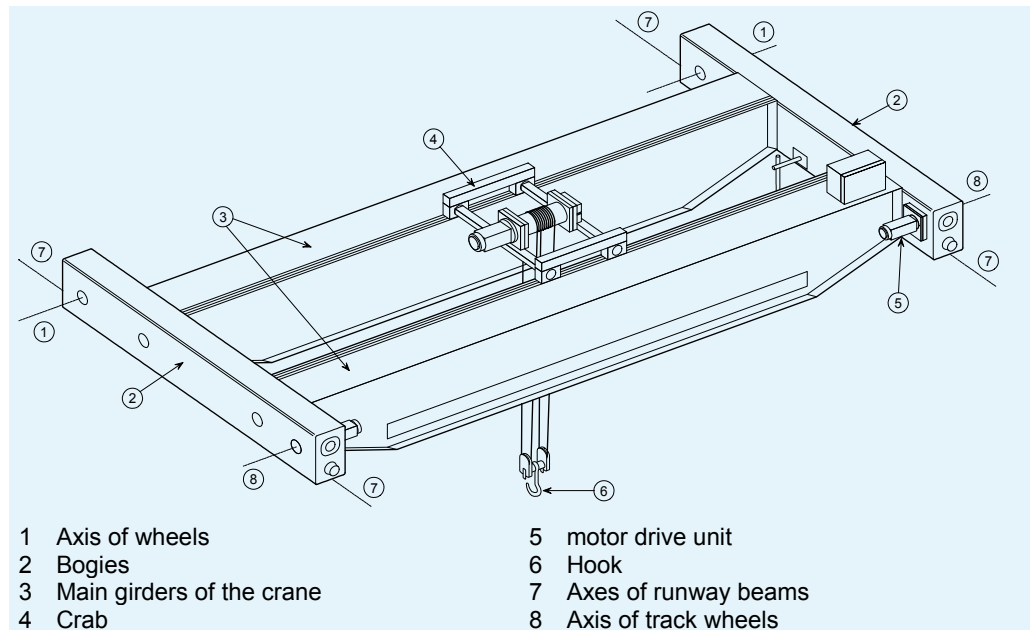

Figure 6.1 Main components of a crane

The relevant standard which specifies these actions is EN 1991-3 ‘Actions on structures – Actions induced by cranes and machinery’.

The variable crane actions are separated into:

- Variable vertical crane actions caused by self weight of the crane and the hoist load
- Variable horizontal actions caused by acceleration or deceleration or by skewing or other dynamic effects.

6.2.2 Vertical actions

Vertical actions include dead loads (self weight of the crane, safe working load, hook block, etc.)

The distribution of these dead loads is generally assumed on the basis of simply supported beams, considering both the main girders and the secondary beams over the bogies.

Two positions of the crab are generally considered to obtain the worst load arrangement on the crane runway: crab located in the middle of the crane span or crab located at the minimum distance of hook approach from the runway.

Considering both crab positions leads to the maximum and minimum loads per wheel acting on the crane runway.

An eccentricity of application for these loads, generally taken as $\frac{1}{4}$ of the rail head, also has to be considered.

In order to consider some features such as impact of wheels at rail joints, wear of rail and wheels, release or lifting of the working load etc., dynamic factors are applied to the above static action values.

For vertical action, the dynamic factors are called φ_1 to φ_4 (refer to Table 2.4 of EN 1991-3).

6.2.3 Horizontal actions

The following types of horizontal forces should be taken into account:

- Horizontal forces caused by acceleration and deceleration of the crane in relation to its movement along the runway beams
- Horizontal forces caused by acceleration and deceleration of the crab in relation to its movement along the crane bridge
- Horizontal forces caused by skewing of the crane in relation to its movement along the runway beam
- Buffer forces related to crane movement
- Buffer forces related to movement of the crab.

Only one of the 5 types of the above horizontal forces should be considered at the same time. The third one is generally assumed to be covered by the fifth one. The two last ones are considered as accidental forces.

The following details considering the first two types are generally those that lead to dimensioning configurations for the crane runway:

1. Forces that result from acceleration and deceleration of the crane along its crane way.

They act at the contact surface between the rail and the wheel. They have to be amplified by a dynamic factor φ_5 (see Table 2.6 of EN 1991-3) whose value may vary from 1,0 to 3,0, the value 1,5 being generally relevant. These forces consist of longitudinal forces (K_1 and K_2) and transverse forces ($H_{T,1}$ and $H_{T,2}$) as shown in Figure 6.2.

The longitudinal forces correspond to the resultant drive force K ; such force must be transmitted through the driven wheels without skidding even when the crane carries no working load.

The resultant of the drive force does not pass through the centre of mass 'S', generating a couple that causes a skewing moment each time the crane accelerates or brakes. This moment is distributed on each runway according to their distance from the centre of mass.

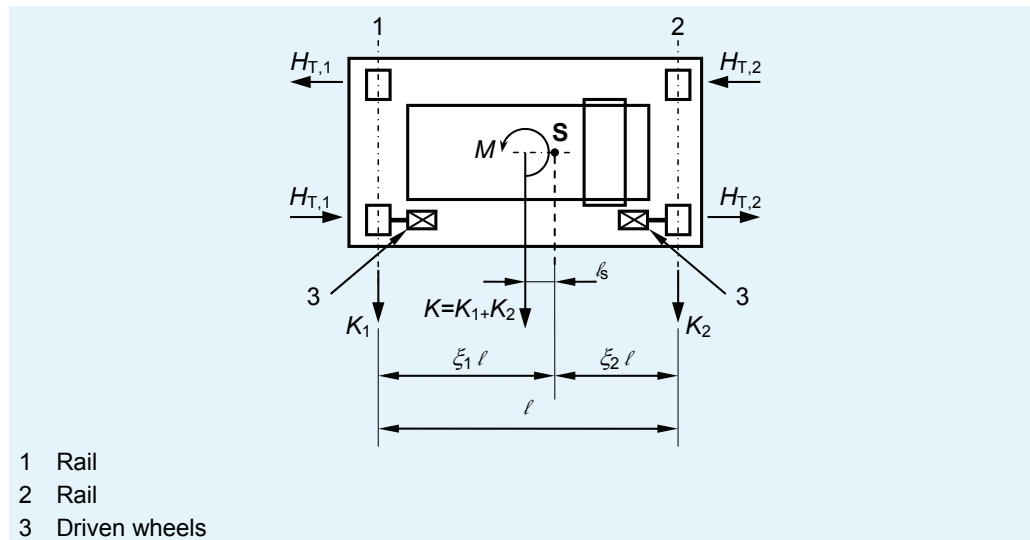

Figure 6.2 Acceleration forces

2 Forces that result from skewing of the crane in relation to its movement along the runway beam

The forces described hereunder are due to the oblique travel of the crane when it assumes a skew position, for any reason, and then continues obliquely until the guidance mean comes in contact with the side of the rail.

The lateral force on the side of the rail increases to reach a peak value 'S'; due to the action of this force, the crane returns to its proper course, at least temporarily.

Guidance systems can be either specific guide roller or the flanges of the track wheels.

The calculation of the corresponding forces depends on the type of drive system (drive units without synchronisation of the driven track wheels or central drive unit coupled to the wheels), the fixing of wheels according to lateral movement and the location of the instantaneous centre of rotation.

Forces resulting from skewing consist of longitudinal and transverse forces such as indicated in Figure 6.3.

These loads act at each wheel ($H_{S,i,j,k}$) and a guide force S (also called steering force) acts at the guidance system.

In the forces $H_{S,i,j,k}$ the indexes refer to:

- S for 'skewing'
- i for beam runway
- j for wheel pair (the number 1 refers to the farthest from the centre of rotation)
- k for direction of the force, L if acting longitudinally or T if acting transversally.

The force S equilibrates the sum of the transverse forces.

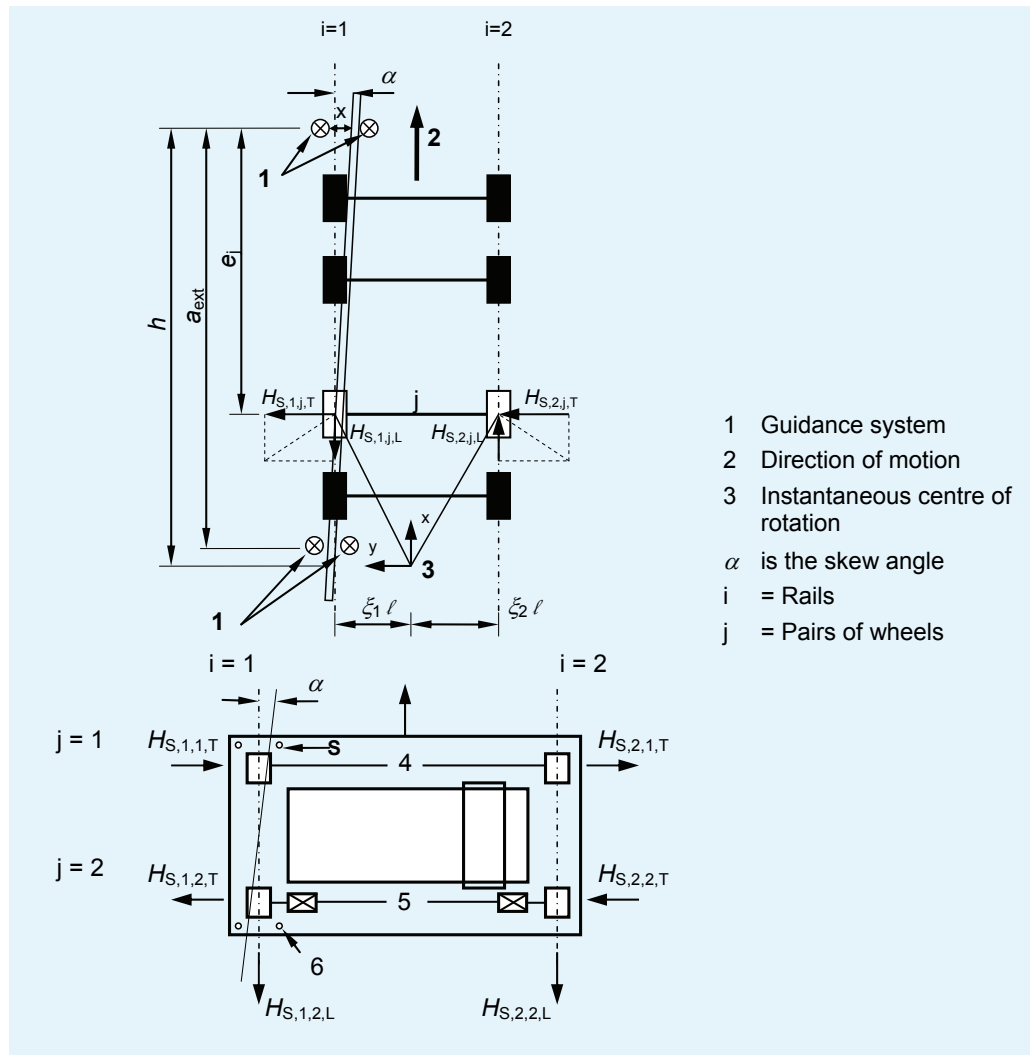

Figure 6.3 Forces resulting from skewing

6.2.4 Other loads or forces

To give an overall picture of the loads induced by cranes, it is necessary to mention:

1. The wind actions on the structure of the crane and on the payload
 The wind is generally considered at a speed of 20 m/s if considered together with the payload (external use).
2. Test loads
 - Dynamic test load: at least 110% of the nominal hoist load, amplified by a dynamic factor φ_6 (see EN 1991-3 §2.10 (4)).
 - Static test load: at least 125% of the nominal hoist load without dynamic factor.
3. Accidental forces
 - Tilting force: when the load or lifting attachments collides with an obstacle.
 - And if relevant: Mechanical failure (failure of a single brake, wheel axle failure, etc.).

6.2.5 Multiple crane action

There is often more than one crane in one building; they can move either on the same runway or on several levels in a same bay or in multi-bay buildings.

Multiple cranes have to be considered in the most unfavourable position for:

- The crane runway
- The supporting structure.

Table 6.1 Recommended maximum number of cranes to be considered in the most unfavourable position

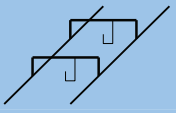
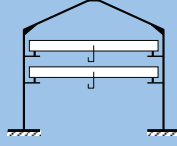
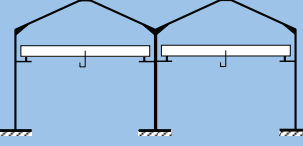
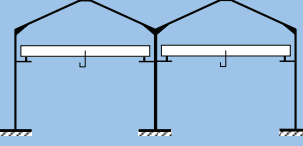
	Cranes to each runway	Cranes in each shop bay	Cranes in multi-bay buildings	
Crane action				
Vertical	3	4	4	2
Horizontal	2	2	2	2

For horizontal crane actions, it is acceptable to limit the number of cranes acting with their payload to two; for vertical actions, the number of cranes varies from two to four.

The cranes which are unloaded have nevertheless to be considered, if unfavourable.

6.3 Horizontal loads on parapets

The characteristic values of the line loads q_k acting at the height of the partition walls or parapets but not higher than 1,20 m should be taken from EN 1991-1-1 Table 6.12 or from the National Annex.

7 SNOW LOADS

7.1 General

This document gives guidance to determine the values of loads due to snow to be used for a typical single-storey building according to EN 1991-1-3. The design procedure is summarized in a flowchart (Figure 7.5). A worked example dealing with the determination of the snow loads on a single-storey building is given in Appendix A.

The guidance does not apply to sites at altitudes above 1500 m (unless otherwise specified).

Snow loads shall be classified as variable, fixed actions, unless otherwise stated in EN 1991-1-3. For particular conditions like exceptional snow loads and/or loads due to exceptional snow drifts, they may be treated as accidental actions depending on geographical locations.

Snow loads should be classified as static actions.

Two design situations may need to be considered:

- Transient/persistent situation should be used for both the undrifted and drifted snow load arrangements for locations where exceptional snow falls and exceptional snow drifts are unlikely to occur.
- Accidental design situation should be used for geographical locations where exceptional snow falls and/or exceptional snow drifts are likely to occur.

The National Annex may define which design situation to apply.

7.2 Methodology

7.2.1 Snow load on the ground

Different climatic conditions will give rise to different design situations. The possibilities are:

- Case A: Normal case (non exceptional falls and drifts)
- Case B1: Exceptional falls and no exceptional drifts
- Case B2: Exceptional drift and no exceptional falls (in accordance with EN 1991-1-3 Annex B)
- Case B3: Exceptional falls and exceptional drifts (in accordance with EN 1991-1-3 Annex B)

The National Authority may choose the case applicable to particular locations for their own territory.

The National Annex specifies the characteristic value s_k of snow load on the ground to be used.

Part 3: Actions

For locations where exceptional snow loads on the ground can occur, they may be determined by:

$$s_{Ad} = C_{esl} s_k$$

where:

- s_{Ad} is the design value of exceptional snow load on the ground for the given location
- C_{esl} is the coefficient for exceptional snow loads (the recommended value is = 2,0)
- s_k is the characteristic value of snow load on the ground for the given location.

The National Annex may recommend another value of C_{esl} , or the design value of exceptional snow load on the ground s_{Ad} .

7.2.2 Snow load on roofs

The load acts vertically and refers to a horizontal projection of the roof area. Snow can be deposited on a roof in many different patterns.

Two primary load arrangements shall be taken into account:

- Undrifted snow load on roofs
- Drifted snow load on roofs.

Snow loads on roofs are derived from the snow loads on the ground, multiplying by appropriate conversion factors (shape, exposure and thermal coefficients). They shall be determined as follows:

- Persistent (conditions of normal use)/transient (temporary conditions) design situations:

$$s = \mu_i C_e C_t s_k$$

- Accidental (exceptional conditions) design situations where exceptional snow load is the accidental action:

$$s = \mu_i C_e C_t s_{Ad}$$

- Accidental design situations where the accidental action is the exceptional drift and where EN 1991-1-3 Annex B applies:

$$s = \mu_i s_k$$

where:

- μ_i is the snow shape coefficient. It depends on the angle of pitch of roof α (Table 6.1)
- C_e is the exposure coefficient ($C_e = 1,0$ is the default value)
- C_t is the thermal coefficient ($C_t \leq 1$; $C_t = 1,0$ is the default value).

The National Annex may give the conditions of use for C_e and C_t .

Table 7.1 Snow load shape coefficients

Angle of pitch of roof α	$0^\circ \leq \alpha \leq 30^\circ$	$30^\circ < \alpha < 60^\circ$	$\alpha \geq 60^\circ$
μ_1	0.8	$0.8 (60 - \alpha)/30$	0
μ_2	$0.8 + 0.8 \alpha/30$	1.6	-

These values μ_1 and μ_2 apply when the snow is not prevented from sliding off the roof (no snow fences or other obstructions like parapets). If obstructions exist, the snow load shape coefficient should not be reduced below 0.8.

The snow load shape coefficient that should be used for monopitch roofs is shown in Figure 7.1, where μ_1 is given in Table 7.1.

The load arrangement should be used for both the undrifted and drifted load arrangements.

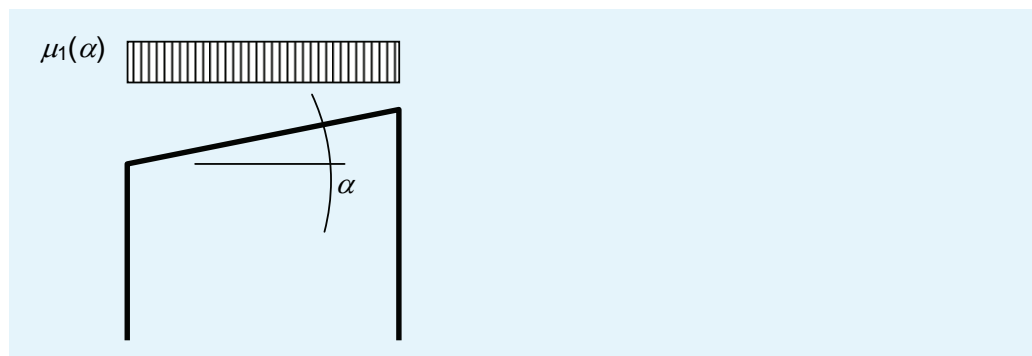

Figure 7.1 Snow load shape coefficient – Monopitch roof

The snow load shape coefficients that should be used for pitched roofs are shown in Figure 7.2, where μ_1 is given in Table 7.1.

Case (i) corresponds to the undrifted load arrangement.

Cases (ii) and (iii) correspond to the drifted load arrangements.

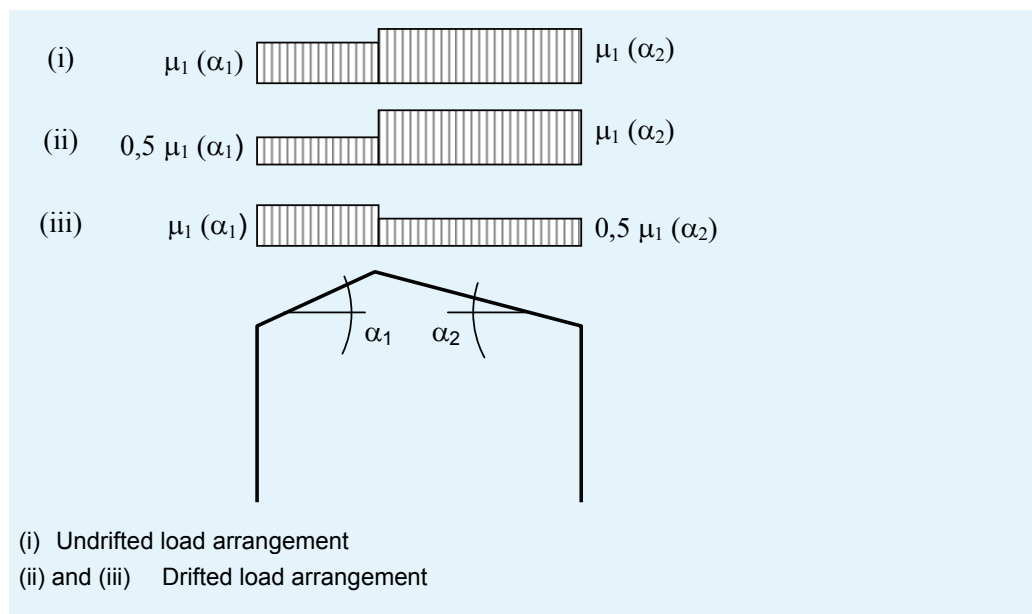

Figure 7.2 Snow load shape coefficient – Pitched roof

The snow load shape coefficients that should be used for multi-span roofs are shown in Figure 7.3, where μ_1 and μ_2 are given in Table 7.1.

Case (i) corresponds to the undrifted load arrangement.

Case (ii) corresponds to the drifted load arrangement.

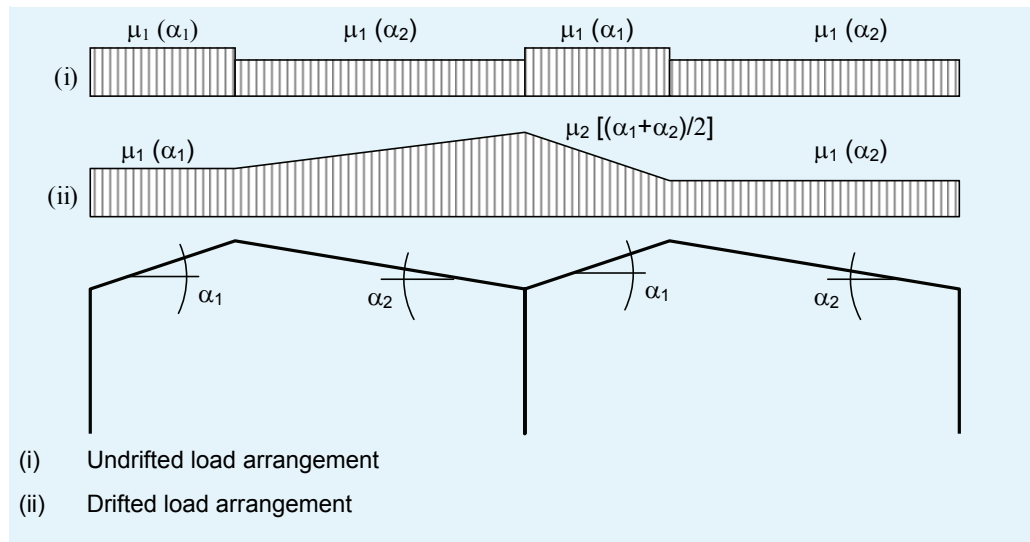

Figure 7.3 Snow load shape coefficient – Multi-span roof

The snow load shape coefficients that should be used for roofs abutting to taller construction works are shown in Figure 7.4, where μ_1 , μ_2 , μ_s , μ_w are given by the following expressions:

$\mu_1 = 0,8$ This value assumes that the lower roof is flat. If it is not, a specific study should be carried out by taking into account the direction of the slope.

$$\mu_2 = \mu_s + \mu_w$$

where:

μ_s is the snow shape coefficient due to sliding of snow from the upper roof.

$$\text{For } \alpha \leq 15^\circ, \mu_s = 0$$

For $\alpha > 15^\circ$, $\mu_s =$ half the snow load on the adjacent slope of the upper roof

μ_w is the snow load shape coefficient due to wind

$$\mu_w = (b_1 + b_2)/2h \quad \text{with } \mu_w \leq \gamma h / s_k$$

And the recommended range is (it may be given in the National Annex):

$$0,8 \leq \mu_w \leq 4$$

b_1 , b_2 and h are defined in Figure 7.4

γ is the weight density of snow for this calculation (2 kN/m^3)

Part 3: Actions

l_s is the drift length determined as :

$$l_s = 2 h$$

The recommended limits of the drift length are (they may be given in the National Annex):

$$5 \text{ m} \leq l_s \leq 15 \text{ m}$$

If $b_2 < l_s$, the coefficient μ_2 is truncated at the end of the lower roof.

The cases (i) corresponds to with the undrifted load arrangement.

The cases (ii) corresponds to with the drifted load arrangements.

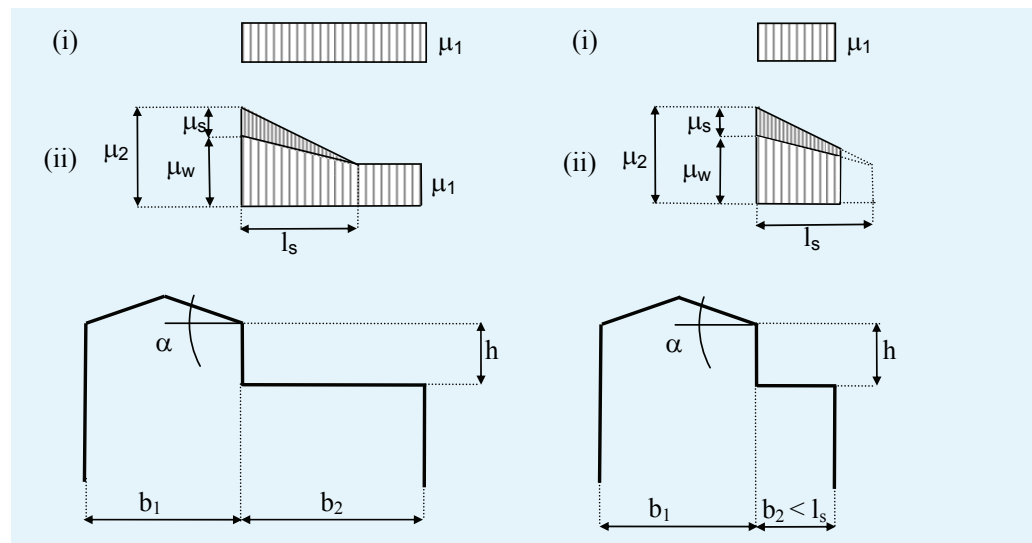

Figure 7.4 Snow load shape coefficient – Roofs abutting to taller construction works

7.2.3 Local effects

The design situations to be considered are persistent/transient. EN 1991-1-3 Section 6 gives forces to be applied for the local verifications of:

- Drifting at projections and obstructions (EN 1991-1-3 § 6.2)
- The edge of the roof (EN 1991-1-3 § 6.3)
- Snow fences (EN 1991-1-3 § 6.4).

7.2.4 Flowchart

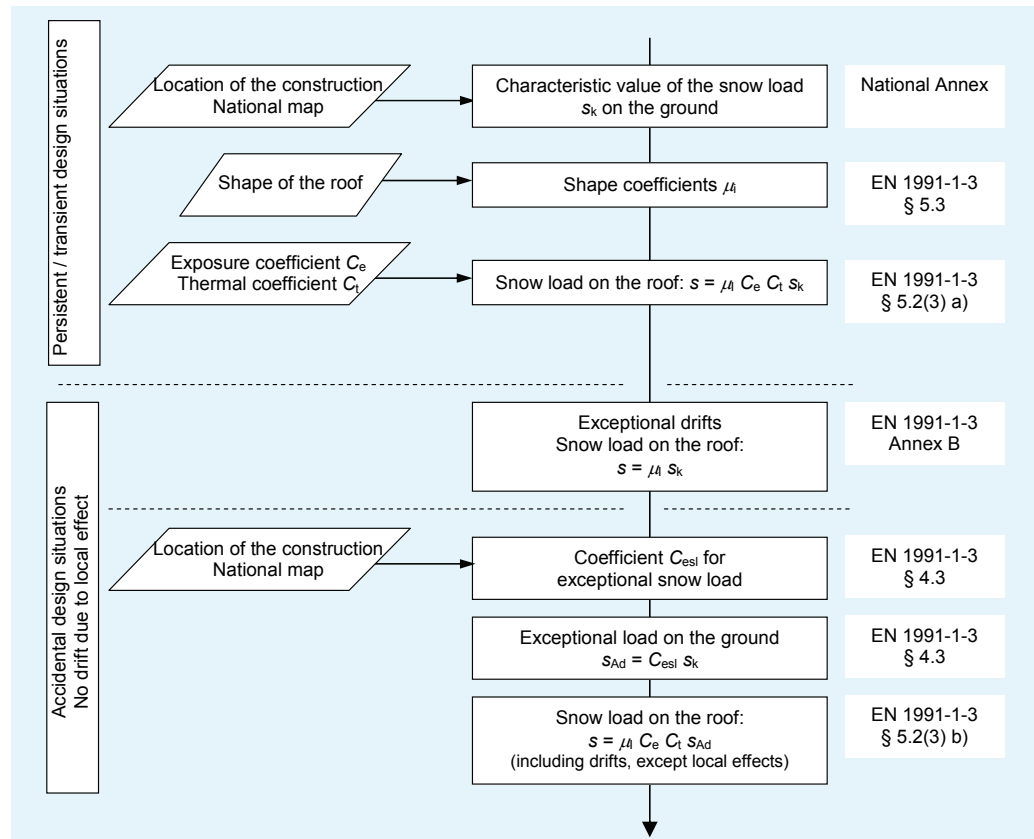

Figure 7.5 Determination of the snow loads

8 WIND ACTIONS

8.1 General

This Section provides guidance to determine the values of the wind action to be used for the design of a typical single-storey building according to EN 1991-1-4. The design procedure is summarized by a flowchart in Figure 8.6 and Figure 8.7. A worked example dealing with the determination of the wind action on a single-storey building is given in Appendix B.

The rules apply to the whole structure or part of the structure, e.g. components, cladding units and their fixings.

A simplified set of pressures or forces whose effects are equivalent to the extreme effects of the turbulent wind represent the wind action.

Wind actions should be classified as variable fixed actions.

The relevant wind actions shall be determined for each design situation identified.

Where, in design, windows and doors are assumed to be shut under storm conditions, the effect of these being open should be treated as an accidental design situation.

8.2 Methodology

The response of the structure to the effect of wind depends on the size, shape and dynamic properties of the structure. This response should be calculated from the peak velocity pressure q_p and from the force and/or pressure coefficients.

8.2.1 Peak velocity pressure

The peak velocity pressure $q_p(z)$ is the velocity pressure used in the calculations.

It depends on the wind climate, the reference height, the terrain roughness and orography. It is equal to the mean velocity pressure plus a contribution from short-term pressure fluctuations.

The peak velocity pressure can be calculated using the following procedure.

1. Fundamental value of the basic wind velocity $v_{b,0}$

The fundamental value of the basic wind velocity is the characteristic 10 minutes mean wind velocity, irrespective of wind direction and time of year, at 10 m above ground level, in open country terrain. It corresponds to a mean return period of 50 years (annual probability of exceedence of 0,02).

The National Annex specifies the fundamental value of the basic wind velocity.

Part 3: Actions

2. Basic wind velocity v_b

$$v_b = c_{dir} c_{season} v_{b,0}$$

where:

c_{dir} is the directional factor

c_{season} is the seasonal factor

The recommended value is 1,0 for both c_{dir} and c_{season} but the National Annex may give other values.

3. Basic velocity pressure

The basic velocity pressure q_b is calculated as follows:

$$q_b = \frac{1}{2} \rho v_b^2$$

where:

ρ is the air density

= 1,25 kg/m³ (recommended value but the National Annex may give another value)

4. Terrain factor k_r

$$k_r = 0,19 \left(\frac{z_0}{z_{0,II}} \right)^{0,07}$$

where:

z_0 is the roughness length according to the terrain category

$z_{0,II}$ is the roughness length for the terrain category II:

$$z_{0,II} = 0,05 \text{ m}$$

$$z_{max} = 200 \text{ m}$$

Terrain categories and terrain parameters are defined in EN 1991-1-4 Table 4.1, but the National Annex may give other values.

5. Roughness factor $c_r(z)$

$$c_r(z) = k_r \ln(z/z_0) \quad \text{for } z_{min} \leq z \leq z_{max}$$

$$c_r(z) = c_r(z_{min}) \quad \text{for } z \leq z_{min}$$

where:

z is the reference height defined by EN 1991-1-4 Figure 7.4.

z_{min} depends on the terrain category, EN 1991-1-4 Table 4.1.

6. Orography factor $c_o(z)$

The orography consists of the study of the shape of the terrain in the vicinity of the construction.

Part 3: Actions

The effects of orography may be neglected when the average slope of the upwind terrain is less than 3°. The recommended value of $c_o(z)$ is 1,0, but the National Annex may give the procedure to calculate the orography factor.

Annex A3 of EN 1991-1-4 gives the recommended procedure to determine c_o for hills, cliffs, etc.

7. Turbulence factor k_1

The recommended value is 1,0 but the National Annex may give other values.

8. Peak velocity pressure $q_p(z)$

$$q_p(z) = [1 + 7I_v(z)] \frac{1}{2} \rho v_m^2(z)$$

where:

$I_v(z)$ is the turbulence intensity which allows to take into account the contribution from short-term fluctuations

$$I_v(z) = \frac{k_1}{c_o(z) \ln(z/z_0)} \quad \text{for } z_{\min} \leq z \leq z_{\max}$$

$$I_v(z) = I_v(z_{\min}) \quad \text{for } z < z_{\min}$$

$$z_{\max} = 200 \text{ m}$$

$v_m(z)$ is the mean wind velocity at height z above the terrain:

$$v_m(z) = c_r(z) c_o(z) v_b$$

Alternative for step 8:

For single-storey-buildings, the determination of the mean wind velocity $v_m(z)$ is not absolutely necessary. The peak velocity pressure can be directly obtained from the exposure factor $c_e(z)$:

$$q_p(z) = c_e(z) q_b$$

where:

$$c_e(z) = \left(1 + \frac{7k_1k_r}{c_o(z)c_r(z)} \right) c_o^2(z) c_r^2(z)$$

For flat terrain ($c_o(z) = 1$) and for turbulence factor $k_1 = 1$, the exposure factor $c_e(z)$ can be directly obtained from Figure 4.2 of EN 1991-1-4, as a function of the height above terrain and a function of terrain category.

8.2.2 Wind pressure on surfaces – Wind forces

There are three types of wind forces acting on a building:

- External forces $F_{w,e}$ (see 8.2.2.1)
- Internal forces $F_{w,i}$ (see 8.2.2.2)
- Friction forces F_{fr} (see 8.2.2.3).

The external and internal forces result in pressures perpendicular to the walls (vertical walls, roofs, etc.). By convention, pressure directed towards the surface is taken as positive, and suction, directed away from the surface as negative (Figure 8.1).

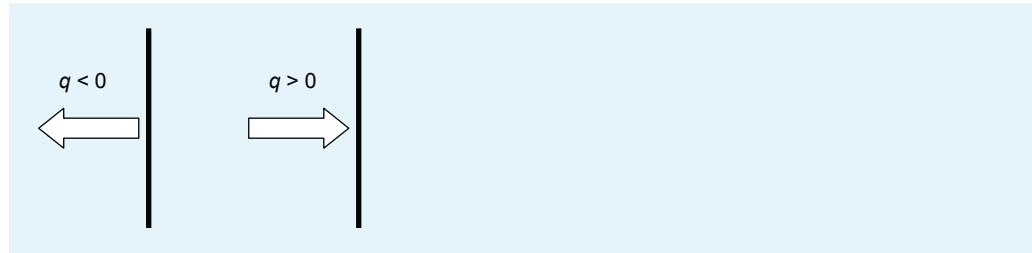

Figure 8.1 Sign convention for the pressure

As stated in EN 1991-1-4 § 5.3(2), the resulting wind force F_w acting on a structure, or a structural component, can be determined by the vector summation of $F_{w,e}$, $F_{w,i}$ and F_{fr} . It can be globally expressed as follows:

$$F_w = c_s c_d c_f q_p(z_e) A_{ref}$$

where:

$c_s c_d$ is the structural factor (for buildings with a height less than 15 m, it may be taken as 1)

Note: the mean wind velocity $v_m(z)$ is necessary to calculate the structural factor $c_s c_d$.

c_f is the force coefficient for the structure (or structural element)

A_{ref} is the reference area of the structure (or structural element). Here it can be defined as the area of the projection of the structure or the structural component, on a vertical plan perpendicular to the wind direction.

Practical approach

In practice, the designer needs to evaluate the resulting pressure on the walls in order to determine the actions on the structural members. The resulting pressure can be expressed as follows:

$$F_w/A_{ref} = c_s c_d w_e - w_i$$

where:

w_e is the wind pressure acting on the external surface (see 7.2.1.2),

w_i is the wind pressure acting on the internal surface (see 7.2.1.3).

In addition the effects of the friction forces (see 7.2.1.4) have to be considered when necessary.

8.2.2.1 External forces

The external forces are obtained from:

$$F_{w,e} = c_s c_d \sum_{\text{surfaces}} w_e A_{\text{ref}}$$

where:

$c_s c_d$ is the structural factor (see 7.2.1.1)

w_e is the wind pressure acting on the external surface:

$$w_e = q_p(z_e) c_{pe}$$

$q_p(z_e)$ is the peak velocity pressure at the reference height z_e

z_e is the reference height for the external pressure (generally, the height of the structure). It depends on the aspect ratio h/b , where h is the height of the building and b is the crosswind dimension.

Generally, h is lower than b for single-storey buildings. In this case, z_e is taken equal to the height of the building and the velocity pressure $q_p(z)$ is uniform on the whole structure: $q_p(z_e) = q_p(h)$.

c_{pe} is the pressure coefficient for the external pressure. See §8.2.3 for vertical walls and §8.2.4 for roofs.

A_{ref} is the reference area. Here it is the area of the surface under consideration for the design of the structure or the structural component.

8.2.2.2 Internal forces

The internal forces are obtained from:

$$F_{w,i} = \sum_{\text{surfaces}} w_i A_{\text{ref}}$$

where:

w_i is the wind pressure acting on the internal surface:

$$w_i = q_p(z_i) c_{pi}$$

z_i is the reference height for the internal pressure (generally: $z_i = z_e$)

$q_p(z_i)$ is the peak velocity pressure at the height z_i (generally: $q_p(z_i) = q_p(z_e)$)

c_{pi} is the pressure coefficient for the internal pressure, see §8.2.5.

8.2.2.3 Friction forces

The friction force results from the friction of the wind parallel to the external surface. Friction is allowed for when the total area of all surfaces parallel to the wind is higher than four times the total area of all external surfaces perpendicular to the wind (windward and leeward), which is the case for long structures.

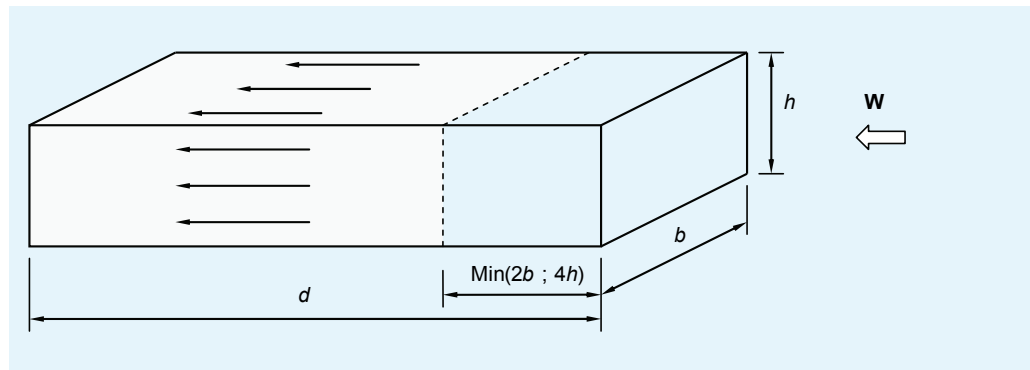

Figure 8.2 Friction forces

The friction forces are obtained from:

$$F_{fr} = c_{fr} q_p(z_e) A_{fr}$$

where:

- c_{fr} is the friction coefficient. It can be taken equal to:
 - 0,01 for smooth surface (steel, smooth concrete, etc.)
 - 0,02 for rough surface (rough concrete, tar-boards, etc.)
 - 0,03 for very rough surface (ripples, ribs, folds, etc.).

$q_p(z_e)$ is the peak velocity pressure at the reference height z_e .

A_{fr} is the reference area. Friction forces are applied on the part of the external surfaces parallel to the wind A_{fr} , located beyond a distance from the upwind eaves or corners, equal to the smallest value of $2b$ or $4h$, b and h as defined in Figure 8.2.

8.2.3 External pressure coefficients on vertical walls

The values of the external pressure coefficients, given in tables in the Eurocode are attached to defined zones. The coefficients depend on the size of the loaded area A that produces the wind action in the zone under consideration. In the tables, the external pressure coefficients are given for loaded areas of 1 m^2 ($c_{pe,1}$) and 10 m^2 ($c_{pe,10}$). In this guide, only the values $c_{pe,10}$ are taken into account, because they are used for the design of the overall load bearing structure of buildings.

Zones for vertical walls are defined in EN 1991-1-4 Figure 7.5 and the external pressure coefficients $c_{pe,10}$ are given in EN 1991-1-4 Table 7.1. For intermediate values of h/d , linear interpolation may apply.

The values of the external pressure coefficients may be given in the National Annex.

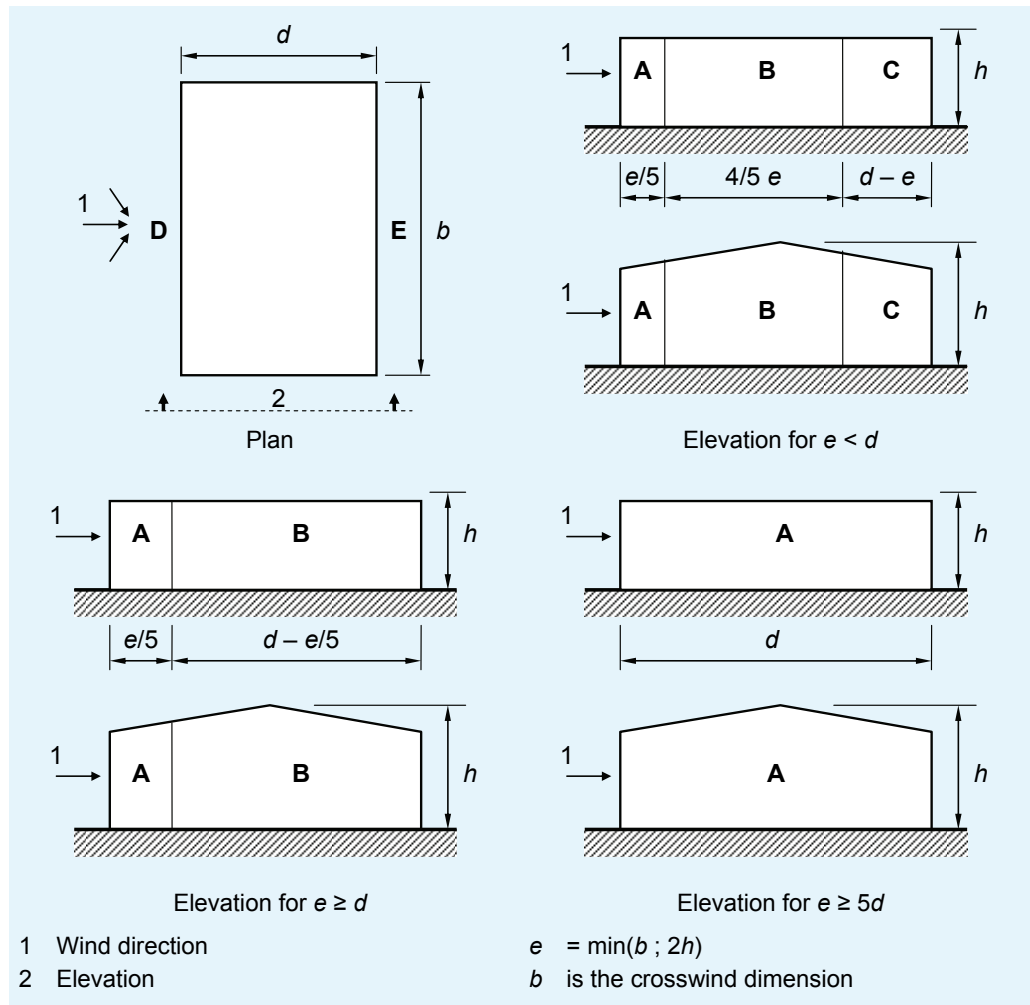

Figure 8.3 Key for vertical walls

For buildings with $h/d > 5$, the total wind loading may be determined by the force coefficients c_f .

In cases where the wind force on building structures is determined by application of the pressure coefficient c_{pe} on windward and leeward side (zones D and E) of the building simultaneously, the lack of correlation of wind pressures between the windward and leeward side may have to be taken into account as follows:

- For buildings with $h/d \geq 5$, the resulting force is multiplied by 1
- For buildings with $h/d \leq 1$, the resulting force is multiplied by 0,85
- For intermediate values of h/d , linear interpolation may be applied.

8.2.4 External pressure coefficients on roofs

Zones for roofs and external coefficients $c_{pe,10}$ attached to these zones are defined in EN 1991-1-4 as follows:

- Flat roofs: Figure 7.6 and Table 7.2
- Monopitch roofs: Figure 7.7 and Tables 7.3a and 7.3b
- Duopitch roofs: Figure 7.8 and Tables 7.4a and 7.4b
- Hipped roofs: Figure 7.9 and Table 7.5

- Multispan roofs : Figure 7.10 and the coefficients c_{pe} are derived from Tables 7.3 to 7.4.

Figure 8.4 of this guide shows the zones for duopitch roofs.

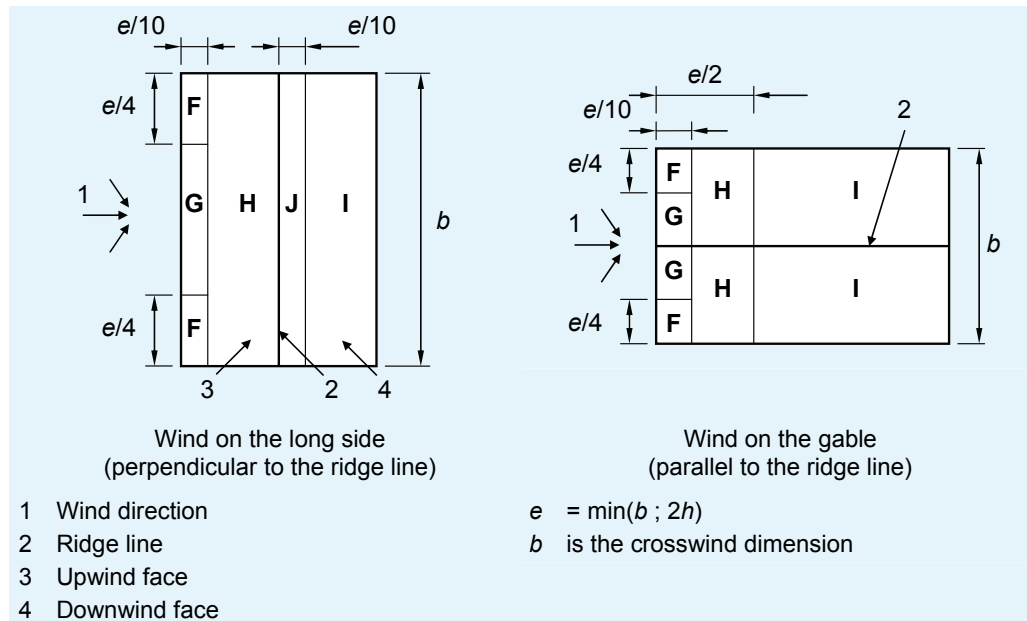

Figure 8.4 Zones for duopitch roofs

8.2.5 Internal pressure coefficients

The internal pressure coefficient c_{pi} depends on the size and distribution of the openings in the building envelope.

When in at least two sides of the building (façades or roof) the total area of openings in each side is more than 30 % of the area of that side, the structure should be considered as a canopy roof and free-standing walls.

A face of a building should be regarded as dominant when the area of openings in that face is at least twice the area of openings in the remaining faces of the building considered.

Where an external opening would be dominant when open but is considered to be closed in the ultimate limit state, during severe windstorms (wind used for the design of the structure), the condition with the opening open should be considered as an accidental design situation.

For a building with a dominant face, the internal pressure should be taken as a fraction of the external pressure at the openings of the dominant face:

- Area of the openings on the dominant face = 2 × area of openings in the remaining faces:
 $c_{pi} = 0,75 c_{pe}$
- Area of the openings in the dominant face = 3 × area of openings in the remaining faces:
 $c_{pi} = 0,90 c_{pe}$

Part 3: Actions

- Area of the openings at the dominant face between 2 and 3 times the area of the openings in the remaining faces:
Linear interpolation for calculating c_{pi} .

When the openings are located in zones with different values of c_{pe} , an area weighted average value should be used.

For buildings without a dominant face, the coefficient c_{pi} should be determined from a function of the ratio h/d and the opening ratio μ for each direction, as shown in Figure 8.5.

where:
$$\mu = \frac{\sum \text{area of openings where } c_{pe} \leq 0}{\sum \text{area of all openings}}$$

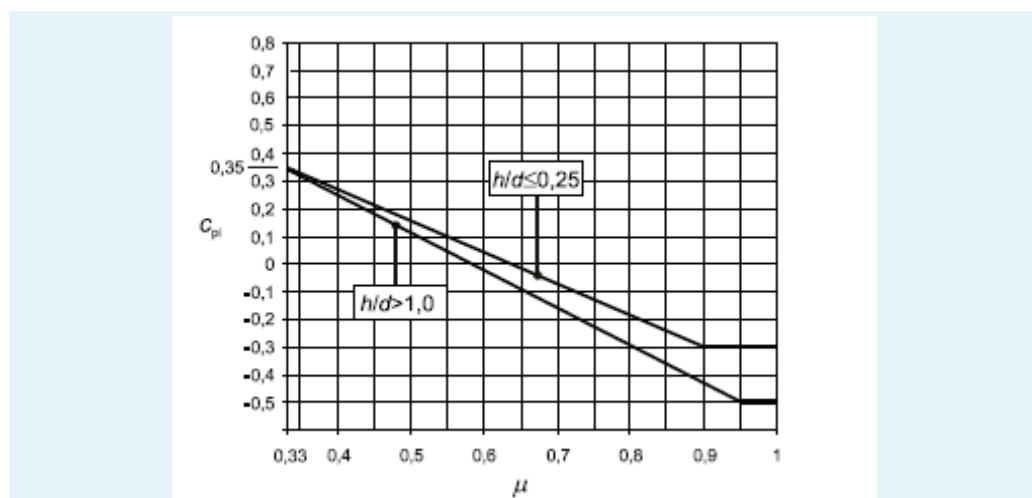

Figure 8.5 Internal pressure coefficients for uniformly distributed openings

For values between $h/d = 0,25$ and $h/d = 1,0$, linear interpolation may be used.

Where it is not possible or not considered justified to estimate μ for a particular case, then c_{pi} should be taken as the more onerous of $+0,2$ and $-0,3$.

The reference height z_i for the internal pressures should be equal to the reference height z_e for the external pressures on the faces which contribute by their openings to the creation of the internal pressure. Generally, for single-storey buildings, $z_i = z_e = h$ and the velocity pressure $q_p(z)$:

$$q_p(z_i) = q_p(z_e) = q_p(h)$$

8.3 Flowcharts

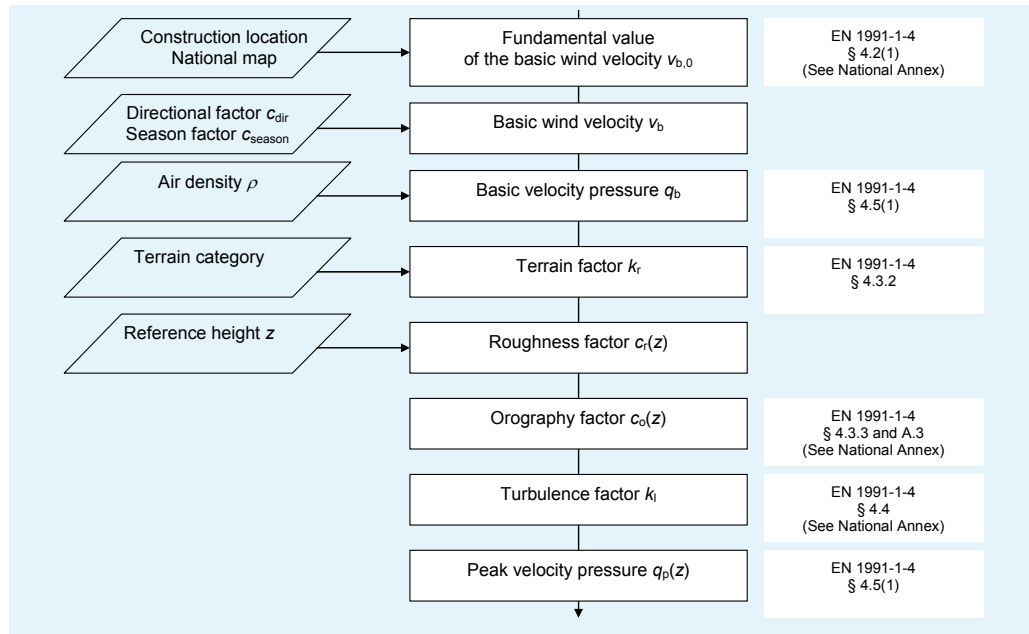

Figure 8.6 Flowchart A: calculation of the peak velocity pressure

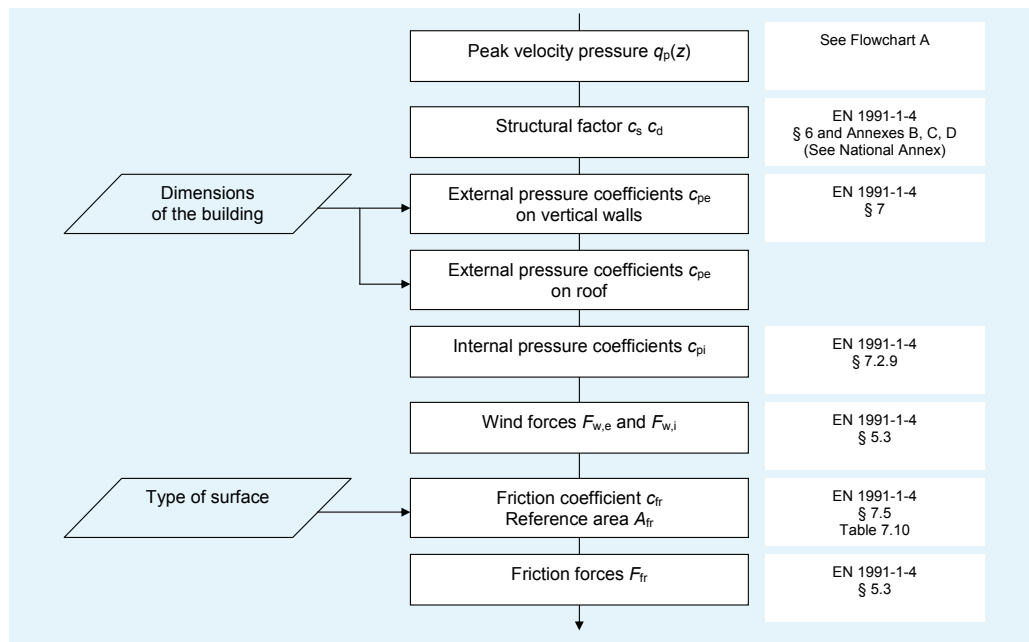

Figure 8.7 Flowchart B: Calculation of the wind forces

9 EFFECT OF TEMPERATURE

Buildings not exposed to daily or seasonal climatic changes may not need to be assessed under thermal actions. For large buildings, it is generally good practice to design the building with expansion joints so that the temperature changes do not induce internal forces in the structure. Information about the design of expansion joints is given in Section 1.4.2 of *Single-storey steel buildings Part 2: Concept design*^[11].

When the effects of temperature have to be taken into account, EN 1993-1-5 provides rules to determine them.

REFERENCES

- 1 EN 1990:2002: Eurocode Basis of structural design
- 2 EN 1991-1-1:2002: Eurocode 1 Actions on structures. General actions. Densities, self-weight, imposed loads for buildings.
- 3 EN 1991-1-3:2003: Eurocode 1 Actions on structures. General actions. Snow loads
- 4 EN 1991-1-4:2005: Eurocode 1 Actions on structures. General actions. Wind actions
- 5 EN 1991-1-5:2003: Eurocode 1 Actions on structures. General actions. Thermal actions
- 6 EN 1991-3:2006: Eurocode 1 Actions on structures. Actions induced by cranes and machinery
- 7 CLAVAUD, D.
Exemple de détermination des charges de neige selon l'EN 1991-1-3. Revue Construction Métallique n°2-2007. CTICM.
- 8 CLAVAUD, D.
Exemple de détermination des actions du vent selon l'EN 1991-1-4. Revue Construction Métallique n°1-2008. CTICM.
- 9 EN 1998-1:2004: Eurocode 8 Design of structures for earthquake resistance. General rules, seismic actions and rules for buildings.
- 10 Steel Buildings in Europe
Multi-storey steel buildings. Part 3: Actions
- 11 Steel Buildings in Europe
Multi-storey steel buildings. Part 2: Concept design

APPENDIX A

Worked Example: Snow load applied on a single-storey building

1. Data

This worked example deals with the single-storey building shown below.

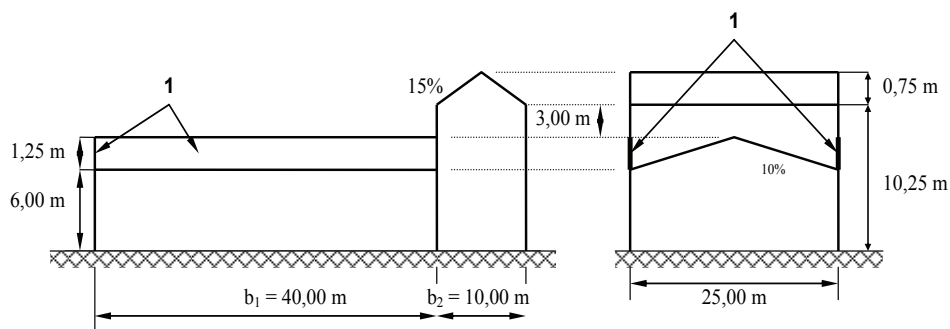
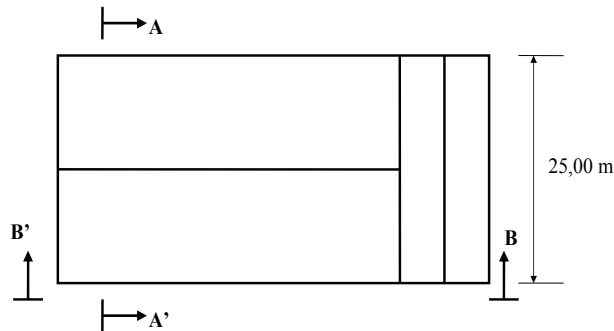

1 Parapets

Figure A.1– Geometry of the building

2. Snow load on the ground

Characteristic value s_k of snow load on the ground:

$$s_k = 0,65 \text{ kN/m}^2$$

Coefficient for exceptional snow load:

$$C_{esl} = 2$$

Exceptional snow on the ground:

$$s_{Ad} = C_{esl} s_k = 2 \times 0,65 = 1,30 \text{ kN/m}^2$$

EN 1991-1-3
§ 4.3

Title	APPENDIX A. Worked Example: Snow load applied on a single-storey building	2 of 8
<p>3. Snow load on the roof</p> <p>3.1. General</p> <p>The loads act vertically and refer to a horizontal projection of the roof area.</p> <p>Two primary load arrangements shall be taken account:</p> <ul style="list-style-type: none"> • undrifted snow load on roofs • drifted snow load on roofs <p>Snow loads on roofs are determined as follows:</p> <ul style="list-style-type: none"> • Persistent (conditions of normal use)/transient (temporary conditions) design situations: $s = \mu_i C_e C_t s_k$ • Accidental design situations (exceptional snow fall) where exceptional snow load is the accidental action: $s = \mu_i C_e C_t s_{Ad}$ • Accidental design situations (exceptional snow drift) where the accidental action is the exceptional drift and where Annex B applies: $s = \mu_i s_k$ <p>where:</p> <p>μ_i is the snow shape coefficient</p> <p>C_e is the exposure coefficient, $C_e = 1,0$</p> <p>C_t is the thermal coefficient, $C_t = 1,0$</p> <p>3.2. Upper roof (duo pitch roof)</p> <p>Angle of the roof (15%):</p> $\alpha = \arctan(0,15) = 8,5^\circ$ $0 \leq \alpha \leq 30^\circ$ <ul style="list-style-type: none"> • Persistent /transient design situations <ul style="list-style-type: none"> - Case (i) : undrifted load arrangement $\mu_1(\alpha = 8,5^\circ) = 0,8$ $s = 0,8 \times 0,65 = 0,52 \text{ kN/m}^2$ - Case (ii): Drifted load arrangement $0,5 \mu_1(\alpha = 8,5^\circ) = 0,4$ $s = 0,4 \times 0,65 = 0,26 \text{ kN/m}^2$ - Case (iii): Drifted load arrangement <p>The case (iii) is symmetrical about the case (ii) because of the symmetry of the roof ($\alpha_1 = \alpha_2 = 8,5^\circ$).</p> 		<p>EN 1991-1-3 §5.2(1)</p> <p>EN 1991-1-3 § 5.2(3) a)</p> <p>§ 5.2(3) b)</p> <p>§ 5.2(3) c)</p> <p>EN 1991-1-3 § 5.3</p> <p>§ 5.2(7)</p> <p>§ 5.2(8)</p> <p>EN 1991-1-3 § 5.3.3 Figure 5.3</p>

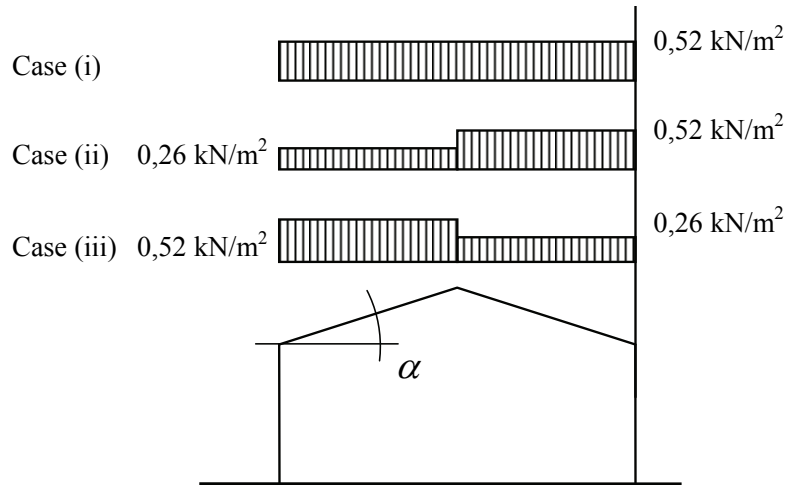

EN 1991-1-3
Figure 5.3

Figure A.2 Snow load arrangements on the upper roof in persistent design situation

- Accidental design situations – exceptional load on the ground

- Case (i): Undrifted load arrangement

$$\mu_1(\alpha = 8,5^\circ) = 0,8$$

$$s = 0,8 \times 1,30 = 1,04 \text{ kN/m}^2$$

- Case (ii): Drifted load arrangement

$$0,5 \mu_1(\alpha = 8,5^\circ) = 0,4$$

$$s = 0,4 \times 1,30 = 0,52 \text{ kN/m}^2$$

- Case (iii): Drifted load arrangement

The case (iii) is symmetrical about the case (ii) because of the symmetry of the roof ($\alpha_1 = \alpha_2 = 8,5^\circ$)

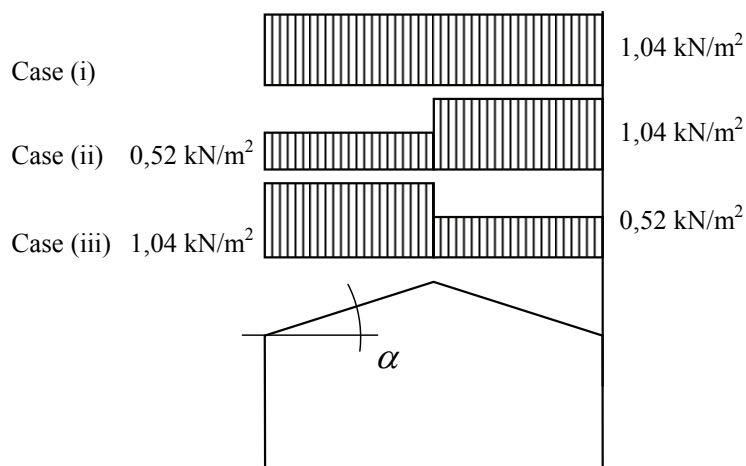

Figure A.3 Snow load arrangements on the upper roof in accidental design situation

- Accidental design situations – exceptional drift:

This case is not applicable. There are no parapets or valleys.

3.3. Lower roof: duo pitch roof abutting to taller construction works

Angle of the roof (10%):

$$\alpha = \arctan(0,10) = 5,7^\circ$$

$$0 \leq \alpha \leq 30^\circ$$

- Persistent /transient design situations
 - Case (i): Undrifted load arrangement

$$\mu_1(5,7^\circ) = 0,8$$

$$s = 0,8 \times 0,65 = 0,52 \text{ kN/m}^2$$

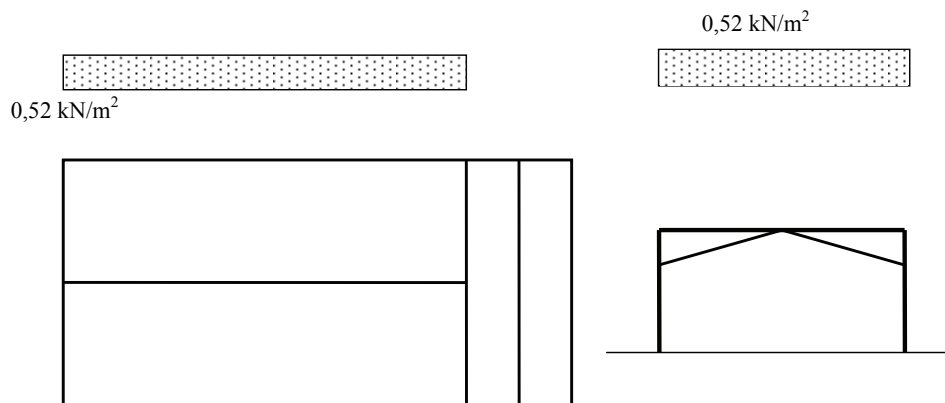

Figure A.4 – Undrifted snow load arrangement on the lower roof in persistent design situation

- Case (ii): drifted load arrangement

$$\mu_1(5,7^\circ) = 0,8$$

$$s = 0,8 \times 0,65 = 0,52 \text{ kN/m}^2$$

$$\mu_2 = \mu_s + \mu_w$$

where:

μ_s is the snow shape coefficient due to sliding of snow from the upper roof.

For $\alpha \leq 15^\circ$: $\mu_s = 0$

μ_w is the snow load shape coefficient due to wind

$$\mu_w = (b_1 + b_2) / 2h$$

with: $\mu_w \leq \gamma h / s_k$

$$b_1 = 10 \text{ m}$$

$$b_2 = 40 \text{ m}$$

h varies between 3 m at ridge to 4,25 m at eaves

$$\gamma = 2 \text{ kN/m}^3$$

EN 1991-1-3
§ 5.3.6(1)

The recommended range is: $0,8 \leq \mu_w \leq 4$

At ridge: $\gamma h/s_k = 2 \times 3/0,65 = 9,2$

$$\mu_w = (10 + 40)/(2 \times 3) = 8,3 \leq \gamma h/s_k$$

At eave: $\gamma h/s_k = 2 \times 4,25/0,65 = 13,1$

$$\mu_w = (10 + 40)/(2 \times 4,25) = 5,9 \leq \gamma h/s_k$$

But μ_w should be maximum 4, so:

$$\mu_w = 4$$

Therefore:

$$s = 4 \times 0,65 = 2,60 \text{ kN/m}^2$$

l_s is the drift length determined as:

$$l_s = 2h$$

This drift length varies between 6 m at ridge to 8,50 m at eaves.

The recommended restriction is: $5 \text{ m} \leq l_s \leq 15 \text{ m}$

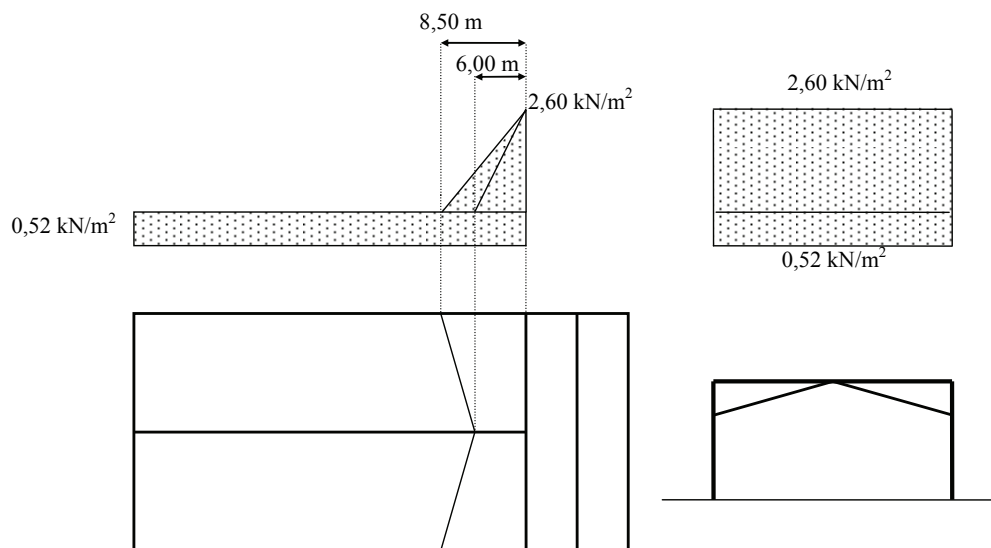

EN 1991-1-3
§ 5.3.6(1)

EN 1991-1-3
Figure 5.7

Figure A.5 Drifted snow load arrangement on the lower roof in the case of abutting to taller construction works in persistent design situation

- Accidental design situations – exceptional load on the ground:

- Case (i): Undrifted load arrangement

$$\mu_1(5,7^\circ) = 0,8$$

$$s = 0,8 \times 1,3 = 1,04 \text{ kN/m}^2$$

The arrangement is the same as Figure A.4 with: $s = 1,04 \text{ kN/m}^2$

- Case (ii): Drifted load arrangement

The arrangement is the same as Figure A.5 with: $s_1 = 1,04 \text{ kN/m}^2$

where:

$$\mu_1 = 0,8$$

$$\text{and } s_2 = 5,20 \text{ kN/m}^2 \text{ where } \mu_w = 4$$

3.4. Lower roof: drifting at obstructions (parapets)

Only persistent/transient design situations are to be considered.

Angle of the roof (10%): $\alpha = 5,7^\circ$

$$\mu_1(5,7^\circ) = 0,8$$

$$s = 0,8 \times 0,65 = 0,52 \text{ kN/m}^2$$

$$\mu_2 = \gamma h/s_k$$

where:

h is the height of parapet. It varies between 0 m at ridge and 1,25 m at low eaves.

$$\gamma = 2 \text{ kN/m}^3$$

$$\text{At ridge: } \mu_2 = 0$$

$$\text{At low eaves: } \mu_2 = 2 \times 1,25/0,65 = 3,8$$

$$\text{With the restriction: } 0,8 \leq \mu_2 \leq 2$$

$\therefore \mu_2$ varies between 0,8 at ridge, and 2 at eave.

s varies between $0,52 \text{ kN/m}^2$ at ridge, and $2 \times 0,65 = 1,30 \text{ kN/m}^2$ at low eaves.

The drift length l_s is determined by: $l_s = 2 h$

This drift length varies between 0 m at ridge and 2,50 m at low eaves.

The recommended restriction is: $5 \text{ m} \leq l_s \leq 15 \text{ m}$. Therefore:

$$l_s = 5 \text{ m at low eaves.}$$

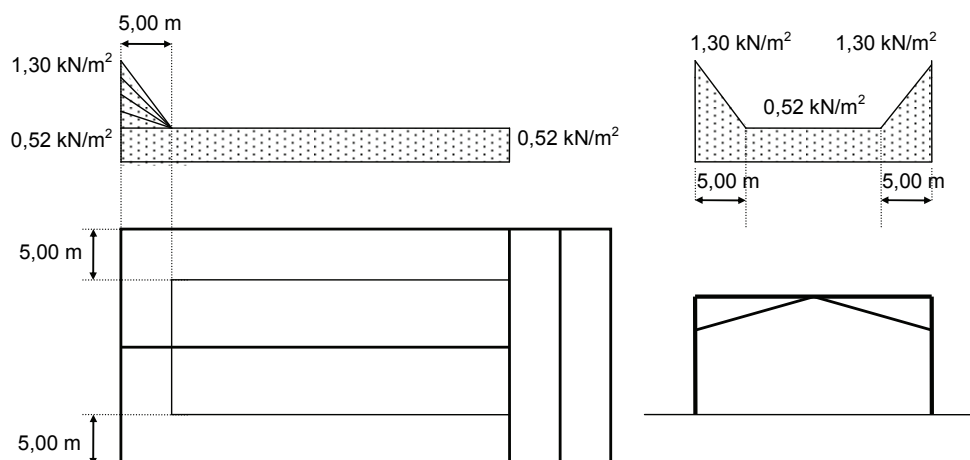

FigureA.6 Drifted snow load arrangement on the lower roof in the case of obstruction in persistent design situation

EN 1991-1-3
§ 6.2(2)

3.5. Exceptional snow drifts

3.5.1. Roofs abutting and close to taller structures

$$\mu_1 = \mu_2 = \mu_3 = \text{Min}(2h/s_k ; 2b/l_s ; 8)$$

where b is the larger of b_1 or b_2

$$l_s = \text{Min}(5h ; b_1 ; 15 \text{ m})$$

$$h = 4,25 \text{ m}$$

$$b_1 = 40,00 \text{ m}$$

$$b_2 = 10,00 \text{ m}$$

$$s_k = 0,65 \text{ kN/m}^2$$

$$5h = 21,25 \text{ m}; l_s = 15,00 \text{ m}; \quad 2h/s_k = 13,08; \quad 2b/l_s = 5,3$$

$$\therefore \mu_1 = \mu_2 = \mu_3 = 5,3$$

And: $s = \mu_3 s_k = 3,45 \text{ kN/m}^2$

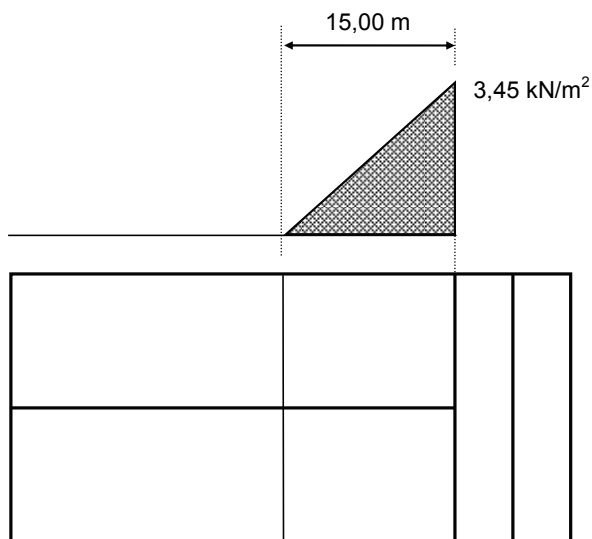

Figure A.7 Exceptional snow drifted on the lower roof in the case of roofs abutting and close to taller building

EN 1991-1-3
Annex B § B.3

3.5.2. Roofs where drifting occurs behind parapets at eaves

$$\mu_1 = \text{Min}(2 h/s_k ; 2 b_2/l_s ; 8)$$

$$\text{where: } l_s = \text{Min}(5h ; b_1 ; 15 \text{ m})$$

$$h = 3,00 \text{ m}$$

$$b_1 = 12,50 \text{ m}$$

$$b_2 = 25,00 \text{ m}$$

$$s_k = 0,65 \text{ kN/m}^2$$

$$5h = 15,00 \text{ m} ; l_s = 12,50 \text{ m} ; 2h/s_k = 9,23 ; 2b_2/l_s = 4,00$$

$$\therefore \mu_1 = 4,00$$

$$\text{And: } s = \mu_1 s_k = 2,60 \text{ kN/m}^2$$

3.5.3. Roofs where drifting occurs behind parapets at gable end

$$\mu_1 = \text{Min}(2 h/s_k ; 2 b_2/l_s ; 8)$$

$$\text{where: } l_s = \text{Min}(5h ; b_1 ; 15 \text{ m})$$

$$h = 3,00 \text{ m}$$

$$b_1 = 40,00 \text{ m}$$

$$b_2 = 25,00 \text{ m}$$

$$s_k = 0,65 \text{ kN/m}^2$$

$$5h = 15,00 \text{ m} ; l_s = 15,00 \text{ m} ; 2h/s_k = 9,23 ; 2b_2/l_s = 5,33$$

$$\therefore \mu_1 = 5,33$$

$$\text{And: } s = \mu_1 s_k = 3,46 \text{ kN/m}^2$$

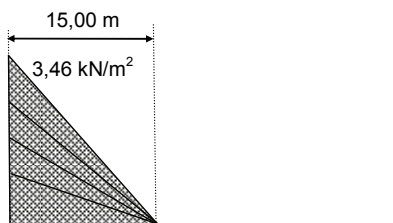

Snow behind the parapet at gable end

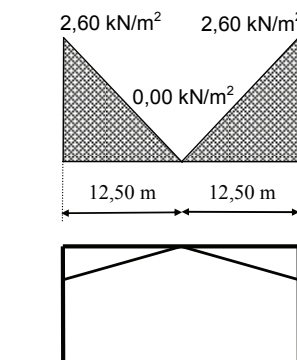

Snow behind the parapets at eaves

Figure A.8 Exceptional snow drifted on the lower roof in the case of roofs where drifting occurs behind parapets at eavesEN 1991-1-3
Annex B § B.4EN 1991-1-3
Annex B § B.4

APPENDIX B

Worked Example: Wind action on a single-storey building

1. Data

This worked example deals with the calculation of the wind action on a single-storey building according to EN 1991-1-4. The overall dimensions of the building are given in Figure B.1.

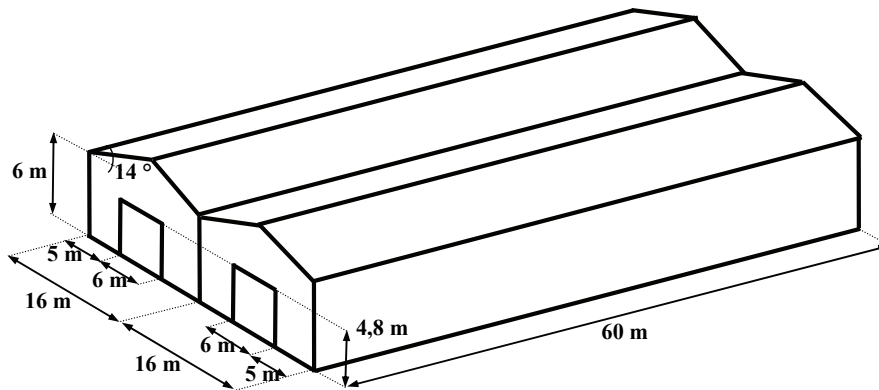

Figure B.1 Geometry of the building

The doors are assumed to be shut during severe gales.

The fundamental value of the basic wind velocity is:

$$v_{b,0} = 26 \text{ m/s}$$

2. Peak velocity pressure

The peak velocity pressure is determined according to the step-by-step procedure given in this guide.

1. Fundamental value of the basic wind velocity

$$v_{b,0} = 26 \text{ m/s}$$

2. Basic wind velocity

For c_{dir} and c_{season} , the recommended values are:

$$c_{dir} = 1,0$$

$$c_{season} = 1,0$$

Then: $v_b = v_{b,0} = 26 \text{ m/s}$

EN 1991-1-4
§ 4.2(2)

Title	APPENDIX B. Worked Example: Wind action on a single-storey building	2 of 11
<p>3. Basic velocity pressure</p> $q_b = \frac{1}{2} \rho v_b^2$ <p>where:</p> $\rho = 1,25 \text{ kg/m}^3 \text{ (recommended value)}$ <p>Then: $q_b = 0,5 \times 1,25 \times 26^2 = 422,5 \text{ N/m}^2$</p> <p>4. Terrain factor</p> $k_r = 0,19 \left(\frac{z_0}{z_{0,II}} \right)^{0,07}$ <p>The terrain category is category III, then:</p> $z_0 = 0,3 \text{ m}$ $z_{\min} = 5 \text{ m}$ $k_r = 0,19 \left(\frac{0,30}{0,05} \right)^{0,07} = 0,215$ <p>5. Roughness factor</p> $c_r(z) = k_r \ln \left(\frac{z}{z_0} \right)$ <p>z is taken equal to the height of the building:</p> $z = 8 \text{ m}$ <p>Then: $c_r(z) = 0,215 \times \ln \left(\frac{8,0}{0,3} \right) = 0,706$</p> <p>6. Orography factor</p> <p>The building is erected on a suburban terrain where the average slope of the upwind terrain is very low ($< 3^\circ$), so:</p> $c_o(z) = 1$ <p>7. Turbulence factor</p> <p>The recommended value is used:</p> $k_1 = 1,0$		<p>EN 1991-1-4 § 4.5(1)</p> <p>EN 1991-1-4 § 4.3.2(1) Table 4.1</p> <p>EN 1991-1-4 § 4.3.2(1)</p> <p>EN 1991-1-4 § 4.3.3(2)</p> <p>EN 1991-1-4 § 4.4(1)</p>

Title	APPENDIX B. Worked Example: Wind action on a single-storey building	3 of 11
<p>8. Peak velocity pressure (alternative for a single-storey building)</p> $q_p(z) = c_e(z) q_b$ <p>where:</p> $c_e(z) = \left(1 + \frac{7k_1 k_r}{c_o(z) c_r(z)} \right) c_o^2(z) c_r^2(z)$ $c_e(z) = \left(1 + \frac{7 \times 1,0 \times 0,215}{1,0 \times 0,706} \right) \times 1,0^2 \times 0,706^2 = 1,56$ <p>Then: $q_p(z) = 1,56 \times 423 = 659 \text{ N/m}^2$ $q_p(z) = 0,659 \text{ kN/m}^2$ for $z = 8 \text{ m}$</p> <p>3. Wind pressure on surfaces</p> <p>3.1. External pressure coefficients $c_{pe,10}$</p> <p>3.1.1. Vertical walls</p> <p>1. Wind on gable</p> <p>$h = 8 \text{ m}$ $b = 32 \text{ m}$ (crosswind dimension) $h < b$, so $z_e =$ reference height $= h = 8 \text{ m}$ $d = 60 \text{ m}$ $h/d = 8/60 = 0,13$ ($h/d < 0,25$) $2h = 16 \text{ m}$ $e = 16 \text{ m}$ (b or $2h$, whichever is smaller) $e < d$ $e/5 = 3,2 \text{ m}$ $4/5 e = 12,8 \text{ m}$ $d - e = 44 \text{ m}$</p> <p>Figure B.2 defines the external pressure coefficients $c_{pe,10}$ on vertical walls for zones A, B, C, D and E with wind on the gable.</p>		<p>EN 1991-1-4 § 4.5(1)</p> <p>EN 1991-1-4 7.2.2 (1) Figure 7.4</p> <p>EN 1991-1-4 7.2.2 (2) Table 7.1</p> <p>EN 1991-1-4 § 7.2.2 (1) Figure 7.5</p> <p>EN 1991-1-4 § 7.2.2(2) Table 7.1</p>

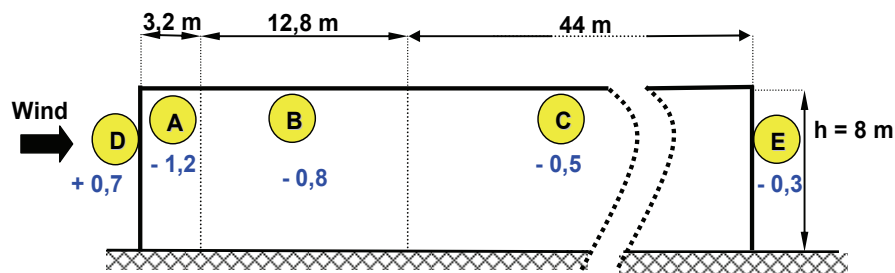

Figure B.2 $c_{pe,10}$ for zones A, B, C, D and E with wind on gable

2. Wind on the long side

$$h = 8 \text{ m}$$

$$b = 60 \text{ m (crosswind dimension)}$$

$$h < b, \text{ so } z_e = \text{reference height} = h = 8 \text{ m}$$

$$d = 32 \text{ m}$$

$$h/d = 8/32 = 0,25$$

$$2h = 16 \text{ m}$$

$$e = 16 \text{ m (} b \text{ or } 2h, \text{ whichever is smaller)}$$

$$e < d$$

$$e/5 = 3,2 \text{ m}$$

$$4/5 e = 12,8 \text{ m}$$

$$d - e = 16 \text{ m}$$

Figure B.3 defines the external pressure coefficients $c_{pe,10}$ on vertical walls for zones A, B, C, D and E with wind on the long side.

EN 1991-1-4
7.2.2 (1)
Figure 7.4

EN 1991-1-4
§ 7.2.2(2)
Table 7.1
EN 1991-1-4
§ 7.2.2(1)
Figure 7.5

EN 1991-1-4
§ 7.2.2(2)
Table 7.1

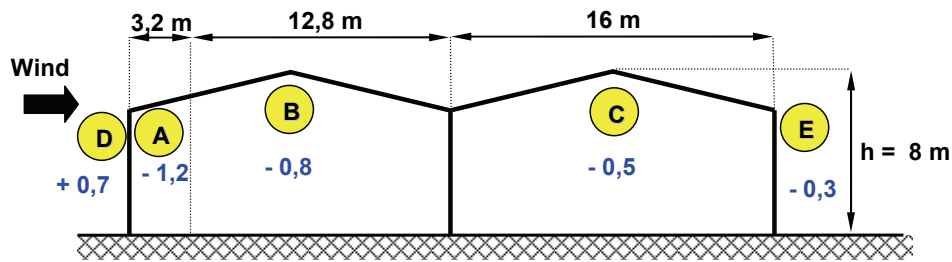

Figure B.3 $c_{pe,10}$ for zones A, B, C, D and E with wind on long side

3.1.2. Roofs

1. Wind on gable

Ridges are parallel to the wind direction: $\theta = 90^\circ$

Pitch angle: $\alpha = 14^\circ$

$h = 8$ m

$b = 32$ m (crosswind dimension)

The reference height is: $z_e = h = 8$ m

$2h = 16$ m

$e = 16$ m (b or $2h$, whichever is smaller)

$e/4 = 4$ m

$e/10 = 1,6$ m

$e/2 = 8$ m

Figure B.4 defines the external pressure coefficients $c_{pe,10}$ on roofs for zones F, G, H and I with a wind on gable.

EN 1991-1-4
§ 7.2.5(1)
Figure 7.8

EN 1991-1-4
§ 7.2.7(3)

EN 1991-1-4
§ 7.2.5(1)
Figure 7.8

EN 1991-1-4
§ 7.2.2(2)
Table 7b

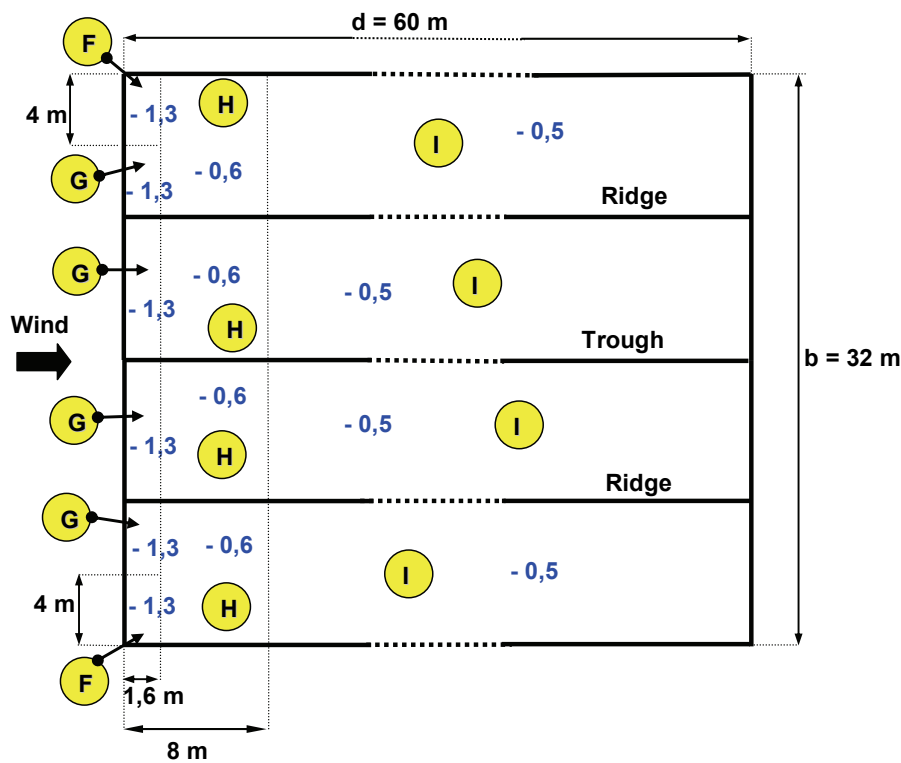

Figure B.4 $c_{pe,10}$ for zones F, G, H and I with wind on gable

2. Wind on long side

- i. Ridges are perpendicular to the wind direction: $\theta = 0^\circ$
- ii. Pitch angle $\alpha = 14^\circ$
- iii. $h = 8$ m
- iv. $b = 60$ m (crosswind dimension)
- v. $h < b$, so the reference height is: $z_e = h = 8$ m
- vi. $d = 32$ m
- vii. $2h = 16$ m
- viii. $e = 16$ m (b or $2h$, whichever is smaller)
- ix. $e/4 = 4$ m
- x. $e/10 = 1,6$ m

Figure B.5 defines the external pressure coefficients $c_{pe,10}$ on roofs for zones F, G, H, I and J with a wind on long side.

EN 1991-1-4
§ 7.2.5(1)
Figure 7.8

EN 1991-1-4
§ 7.2.5(1)
Figure 7.8

EN 1991-1-4
§ 7.2.7(2)
Figure 7.10c

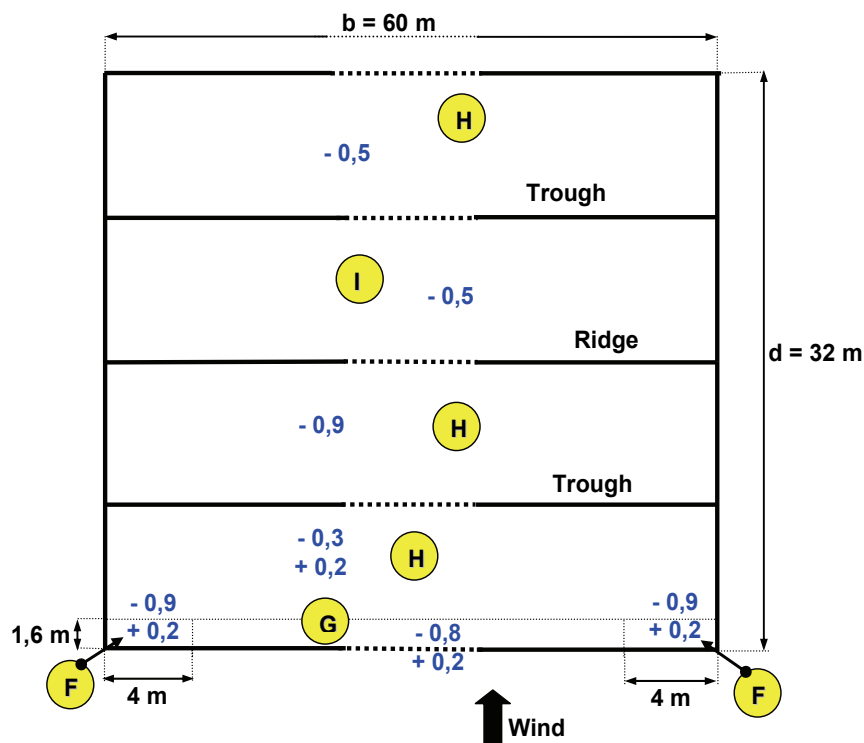

Figure B.5 $c_{pe,10}$ for zones F, G, H and I with wind on long side

3.2. Internal pressure coefficients c_{pi}

3.2.1. Persistent or transient design situation

The doors are assumed to stay shut during severe gales:

$$c_{pi} = +0,2$$

And $c_{pi} = -0,3$

with reference height for the internal pressure: $z_i = z_e = h = 8\text{ m}$

3.2.2. Accidental design situation

- A door opens upwind (wind on gable): this face is dominant and area of the openings at the dominant face = $3 \times$ area of the openings in the remaining faces:

$$c_{pi} = 0,90 c_{pe}$$

$$c_{pi} = 0,90 \times (+0,7) = +0,63$$

- A door opens downwind (wind on long side): this face is dominant and area of the openings at the dominant face = $3 \times$ area of openings in the remaining faces.

EN 1991-1-4
§ 7.2.9(6)

§ 7.2.9(7)

EN 1991-1-4
§ 7.2.9(3)

§ 7.2.9(5)

Title	APPENDIX B. Worked Example: Wind action on a single-storey building	8 of 11
<p>The most severe case is when the opening is in a zone where c_{pe} is the highest (the door is completely in zone B).</p> $c_{pi} = 0,90 c_{pe}$ $c_{pi} = 0,90 \times -0,8 = -0,72$ <p>4. Friction forces</p> <p>4.1. Wind on gable</p> <p>The area of the external surfaces parallel to the wind is calculated by:</p> $60 \times 2 \times (6 + 8,25 \times 2) = 2700 \text{ m}^2$ <p>The area of the external surfaces perpendicular to the wind is:</p> $2 \times 2 \times 16 \times (6 + 1) = 448 \text{ m}^2$ <p>The area of the external surfaces parallel to the wind is higher than $4 \times$ area of external surfaces perpendicular to the wind: friction forces should be taken into account:</p> $4 h = 32 \text{ m}$ $2 b = 64 \text{ m}$ $4 h < 2 b$ <p>The friction forces apply on the area A_{fr}:</p> $A_{fr} = 2 \times (60 - 32) \times (6 + 8,25 \times 2) = 1260 \text{ m}^2$ <p>For a smooth surface (steel):</p> $c_{fr} = 0,01$ <p>and the friction force F_{fr} (acting in the direction of the wind):</p> $F_{fr} = c_{fr} q_p(z_e) A_{fr} = (0,01 \times 66 \times 1260) 10^{-2} = 8,316 \text{ kN}$ $4 h < 2 b$ <p>The friction forces apply on the area A_{fr}:</p> $A_{fr} = 2 \times (60 - 32) \times (6 + 8,25 \times 2) = 1260 \text{ m}^2$ <p>For a smooth surface (steel):</p> $c_{fr} = 0,01$ <p>and the friction force F_{fr} (acting in the direction of the wind):</p> $F_{fr} = c_{fr} q_p(z_e) A_{fr} = (0,01 \times 66 \times 1260) 10^{-2} = 8,316 \text{ kN}$ <p>4.2. Wind on long side</p> <p>Area of external surfaces parallel to the wind $< 4 \times$ area of external surfaces perpendicular to the wind: friction forces should not be taken account</p>		<p>EN 1991-1-4 § 7.2.9(6)</p> <p>EN 1991-1-4 § 5.3(4)</p> <p>EN 1991-1-4 § 7.5(3)</p> <p>EN 1991-1-4 § 5.5(3)</p> <p>EN 1991-1-4 § 7.5(3)</p> <p>EN 1991-1-4 § 5.5(3)</p> <p>EN 1991-1-4 § 5.3(4)</p>

5. Wind forces on surfaces

$$F/A_{\text{ref}} = c_s c_d q_p(z_e) c_{pe} - q_p(z_i) c_{pi}$$

with: $c_s c_d = 1$ (height < 15 m)

$$q_p(z_e) = q_p(z_i) = 0,66 \text{ kN/m}^2$$

The figures below show the wind forces per unit surfaces:

$$F/A_{\text{ref}} = 0,66 (c_{pe} - c_{pi}) \text{ (in kN/m}^2\text{)}$$

EN 1991-1-4
§ 6.2(1)b

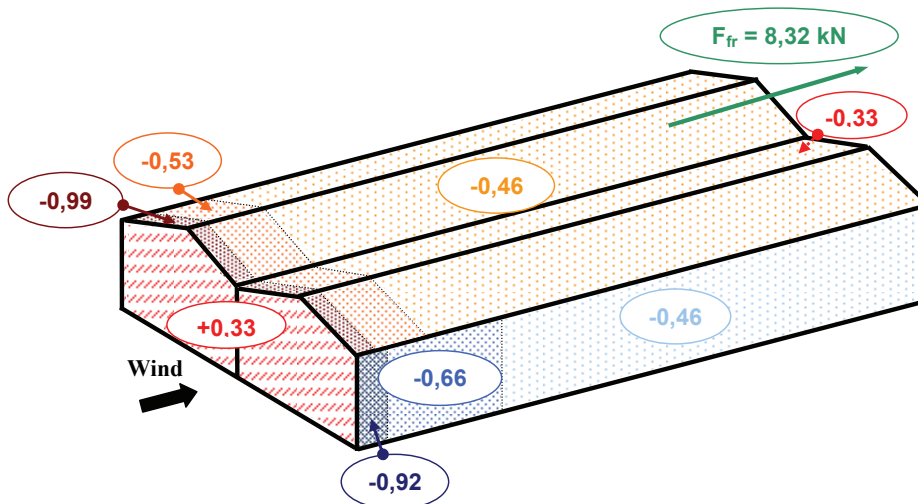

Figure B.6 Wind on gable with $c_{pi} = +0,2$

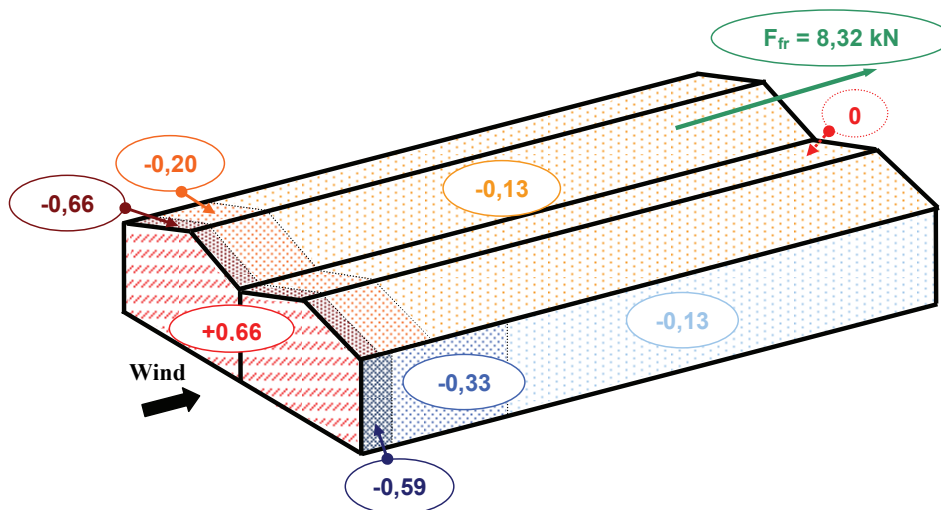

Figure B.7 Wind on gable with $c_{pi} = -0,3$

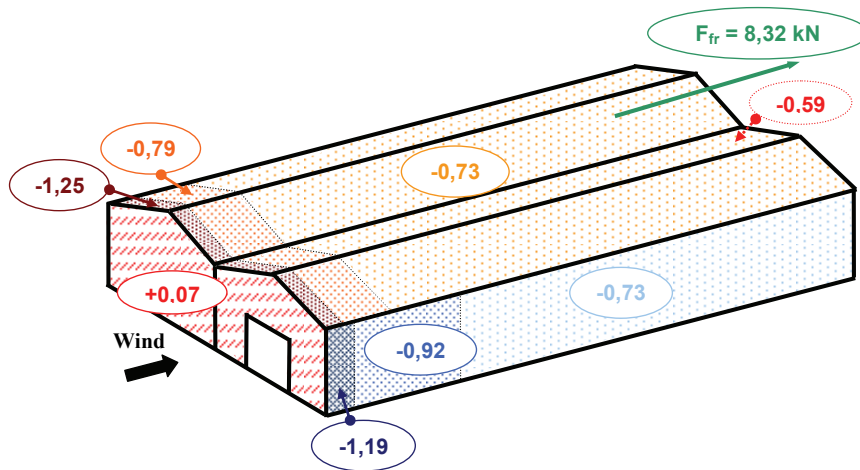

Figure B.10 Accidental design situation: door open upwind (wind on gable) with $c_{pi} = +0,6$

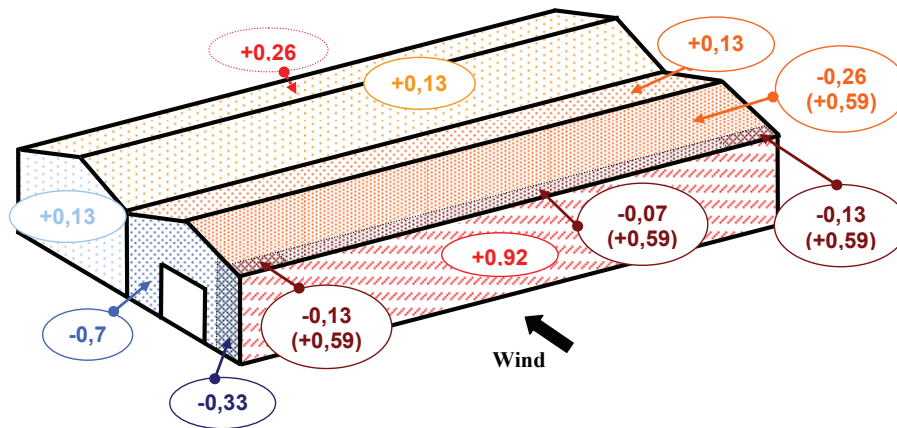

Figure B.11 Accidental design situation: door open downwind (wind on long side) with $c_{pi} = -0,7$

Values in brackets should be used together